



Premium wheel-end brake products

Bendix® EB™ & ES™ Air Drum Brakes

Service Manual

Section 1: General Information

Foreword	4
Lining Material Warning	5
Model Coverage	6
Parts Nomenclature	8
Model ES-165-7 and EB-165-7 Interchangeability	12
EB™ Roller and ES™ Cam Interchangeability	12

Section 2: Periodic Service

Brake Maintenance Preliminary Steps	15
Brake Adjustment	15
Brake Operation Check	17
Lubrication	17
Periodic Inspections	18
Service Intervals	18

Section 3: Removal/Disassembly

Drum Removal	19
Shoe Removal	20
EB models (except EB-150-4L)/ES-165-5, 6, 7D, F, L/ES-150-8D, F/ES-150-6D	21
ES-150-4L and EB-150-4L	23
ES-165-7M	24
ES-165-7H	26
Brake Adjuster Removal	28
Camshaft Removal	28
Air Chamber Bracket Removal	28
Spider Removal	29
Dustshield Removal	29
Cleaning Brake Parts	30

Section 4: Inspection

Drum Inspection	31
Shoe and Lining Inspection	32
Camshaft Radial Play Inspection	34
Camshaft Inspection	34
Camshaft Bushing and Seal Inspection	34
Spider Inspection	35
Air Chamber Bracket Inspection	35
Air Chamber Inspection	36
Brake Adjuster Inspection	36

Section 5: Repair/Replacement

Camshaft Bushing/Grease Seal Replacement	37
Lining Replacement	38

Section 6: Installation/Assembly

Spider Installation	39
Dustshield Installation (Two Piece)	39
Dustshield Installation (One Piece)	40
Air Chamber Bracket Installation	41
Camshaft Installation	42
Cam Head Washer Installation	42
Brake Adjuster Installation	43
Shoe and Lining Installation	44
Shoe Installation	46
ES-150-8D, F & 6D	46
All EB (except EB-150-4L) and ES-165-5, 6, 7D, F, L	47
ES-165-7M	49
ES-165-7H	51

Specification Chart	57
----------------------------------	-----------



List of Illustrations and Tables

List of Illustrations

Figure 1. How to Use this Manual 4

Figure 2. Bendix Brake Model Identification 5

Figure 3. Brake Part Nomenclature, General 6

Figure 4. Brake Model Part Nomenclature 7

Figure 4. Brake Model Part Nomenclature, Continued 8

Figure 5. EB™ Roller and ES™ Cam Contact Pattern 12

Figure 6. Parts Identification 13

Figure 6. Parts Identification, Continued 14

Figure 7. Vehicle Maintenance Support 15

Figure 8. Measurement, At Rest 15

Figure 9. Measurement, 80 psi Applied 16

Figure 10. Measurement, Brake Applied 16

Figure 11. Brake Adjuster Adjustment 16

Figure 12. Roller Retainer Removal 21

Figure 13. Upper Cam Roller and Pin Removal 21

Figure 14. ES-165-7D, L, F Shoe Removal 22

Figure 15. Shoe Removal 22

Figure 16. Shoe Return Spring Removal 23

Figure 17. Lower Shoe Removal 23

Figure 18. Retainer Loop Removal 24

Figure 19. Roller and Retainer Removal 24

Figure 20. Return Spring Removal 24

Figure 21. Retaining Ring and Washer Removal 25

Figure 22. Cap Screw Removal 25

Figure 23. Anchor Pin Removal 25

Figure 24. Anchor Pin Bushing Removal 25

Figure 25. Retaining Ring and Washer Removal 26

Figure 26. Cap Screw Removal 26

Figure 27. Anchor Pin Removal 26

Figure 28. Shoe Removal 26

Figure 29. Anchor Pin Bushing Removal 27

Figure 30. Groove Pin Removal 27

Figure 31. Brake Adjuster Removal 28

Figure 32. Spider Mounting Hardware Removal 29

Figure 33. Dustshield Mounting Hardware Removal 29

Figure 34. Drum Inspection 31

Figure 35. Cam Roller Identification 31

Figure 36. Shoe and Lining Inspection 32

Figure 37. Brake and Lining Blocks 33

Figure 38. Camshaft Radial Play Inspection 34

Figure 39. Camshaft Inspection 34

Figure 40. Spider Inspection 35

Figure 41. Air Chamber Bracket Inspection 35

Figure 42. Air Chamber Inspection 36

Figure 43. Brake Adjuster Inspection 36

Figure 44. Air Chamber Bracket Bushing Installation 37

Figure 45. Camshaft Bushing Installation 37

Figure 46. Lining Rivet (or Bolt) Tightening Sequence 38

Figure 47. Installing Spider Mounting Hardware 39

Figure 48. Dustshield Spacing 39

Figure 49. Designed Interference Fit 39

Figure 50. Attaching Screw Location 40

Figure 51. Air Chamber Bracket Mounting Hardware 41

Figure 52. Camshaft Installation 42

Figure 53. Cam Head Washer Installation 42

Figure 54. Shim Washer and Snap Ring Installation 43

Figure 55. Brake Adjuster End Play Check 43

Figure 56. Brake Adjuster Lubrication and Adjustment 43

Figure 57. Shoe Web Lubrication 45

Figure 58. Shoe Retaining Spring Installation 45

List of Illustrations

Figure 59. Shoe Return Spring and Roller Installation	45
Figure 60. Upper and Lower Shoe Positioning	46
Figure 61. Shoe Return Spring Installation	46
Figure 62. Upper and Lower Shoe Positioning	47
Figure 63. Shoe Return Spring Installation	47
Figure 64. Roller Retainer Installation	48
Figure 65. Shoe Return Spring Installation	48
Figure 66. Retainer Installation	48
Figure 67. Anchor Pin Bushing Installation	49
Figure 68. Lower Shoe and Anchor Pin Installation	49
Figure 69. Upper Shoe and Anchor Pin Installation	49
Figure 70. Cap Screw Installation	49
Figure 71. Shoe Return Spring Installation	50
Figure 72. Roller Retainer Installation	50
Figure 73. Roller and Retainer Installation	50
Figure 74. Retainer Installation	50
Figure 75. Groove Pin Installation	51
Figure 76. Spider Anchor Pin Bushing Installation	51
Figure 77. Shoe Anchor Pin Bushing Installation	51
Figure 78. Lower Shoe Positioning	52
Figure 79. Upper Shoe Positioning	52
Figure 80. Upper Shoe Installation	52
Figure 81. Lower Shoe and Anchor Pin Installation	52

List of Tables

Table 1. Bendix Brake Models and Specifications	4
Table 2. Distance Range	15
Table 3. Stroke Values	16
Table 4. Lubrication Intervals	17
Table 5. Shoe Removal Procedure Index	20
Table 6. Distance: Clevis Pin Hole Centerline to Air Chamber Face	36
Table 7. Camshaft Bushing Installation Specifications	37
Table 8. Shoe Installation Procedure Index	44



Foreword/Lining Material Warning

Purpose of this Manual

This Bendix Spicer Foundation Brake LLC publication is intended to act as a source of maintenance information to those involved in servicing Bendix brakes.

How to Use this Manual

1. Arrangement. This manual is arranged in seven sections: General Information, Periodic Service, Removal/Disassembly, Inspection, Repair/Replacement, Installation/Assembly and Specifications. General page layout, including section and paragraph headings, indentation levels, and Figure and Table designator information, is shown in Figure 1.
2. Table of Contents. The Table of Contents lists all section headings and primary paragraph headings in this publication.
3. Illustrations and Tables. Illustrations and tables are included to help make the text of this publication clear. See the List of Illustrations and List of Tables following the Table of Contents.
4. Specification Chart. A tabulation of all measurement specifications is provided at the back of this publication.



AVOID CREATING DUST POSSIBLE CANCER AND LUNG DISEASE HAZARD

While Bendix Spicer Foundation Brake LLC does not offer asbestos brake linings, the long-term effects of some non-asbestos fibers have not been determined. Current OSHA Regulations cover exposure levels to some components of non-asbestos linings but not all. The following precautions must be used when handling these materials.

1. AVOID CREATING DUST. Compressed air or dry brushing must never be used for cleaning brake assemblies or the work area.

2. BENDIX SPICER FOUNDATION BRAKE LLC RECOMMENDS THAT WORKERS DOING BRAKE WORK MUST TAKE STEPS TO MINIMIZE EXPOSURE TO AIRBORNE BRAKE LINING PARTICLES. Proper procedures to reduce exposure include working in a well ventilated

area, segregation of areas where brake work is done, use of local filtered ventilation systems or use of enclosed cells with filtered vacuums. Respirators approved by the Mine Safety and Health Administration (MSHA) or National Institute for Occupational Safety and Health (NIOSH) should be worn at all times during brake servicing.

3. Workers must wash before eating, drinking or smoking; shower after working, and should not wear work clothes home. Work clothes should be vacuumed and laundered separately without shaking.

4. Material safety data sheets on this product, as required by OSHA, are available from Bendix Spicer Foundation Brake LLC.



Model Coverage

The service procedures and specifications in this publication cover the Bendix brake models listed in Table 1. The basic instructions cover all 15", 16.5", and 18" brake types and sizes, unless specified otherwise. A breakdown of Bendix brake model identification is provided in Figure 2.

Brake Model	Size		Configuration			Applications
	in.	mm	Shoe	Spider	Anchor	
EB-150-4L	15.0 x 4	381 x 102	Fabricated	Fabricated	SAP	Steer Axles
EB-165-5D	16.5 x 5	419 x 127	Fabricated	Cast	SAP	Steer or Drive Axles
EB-165-5L	16.5 x 5	419 x 127	Fabricated	Fabricated	SAP	Steer or Drive Axles
EB-165-6D	16.5 x 6	419 x 152	Fabricated	Cast	SAP	Steer or Drive Axles
EB-165-6L	16.5 x 6	419 x 152	Fabricated	Fabricated	SAP	Steer or Drive Axles
EB-165-7D	16.5 x 7	419 x 178	Fabricated	Cast	SAP	Steer or Drive Axles
EB-165-7F	16.5 x 7	419 x 178	Fabricated	Forged	SAP	Trailer Axles
EB-165-7L	16.5 x 7	419 x 178	Fabricated	Fabricated	SAP	Steer or Drive Axles
EB-165-8D	16.5 x 8.63	419 x 219	Fabricated	Cast	SAP	Drive Axles
EB-165-8L	16.5 x 8.63	419 x 219	Fabricated	Fabricated	SAP	Drive Axles
EB-180-7R	18.0 x 7	457 x 178	Cast	Heavy Cast	SAP	On/Off Hwy. Drive Axles
ES-150-4L	15.0 x 4	381 x 102	Fabricated	Fabricated	SAP	Steer Axles
ES-150-4D	15.0 x 4	381 x 102	Fabricated	Cast	SAP	Steer Axles
ES-150-6D	15.0 x 6	381 x 152	Fabricated	Cast	SAP	Steer or Drive Axles
ES-150-8D	15.0 x 8.63	381 x 219	Fabricated	Cast	SAP	Drive Axles
ES-150-8F	15.0 x 8.63	381 x 219	Fabricated	Forged	SAP	Trailer Axles
ES-165-5D	16.5 x 5	419 x 127	Fabricated	Cast	SAP	Steer or Drive Axles
ES-165-5L	16.5 x 5	419 x 127	Fabricated	Fabricated	SAP	Steer or Drive Axles
ES-165-6D	16.5 x 6	419 x 152	Fabricated	Cast	SAP	Steer or Drive Axles
ES-165-6L	16.5 x 6	419 x 152	Fabricated	Fabricated	SAP	Steer or Drive Axles
165 XL Cast	16.5 x 6	419 x 152	Cast	Cast	DAP	Steer Axle Transit
ES-165-7D	16.5 x 7	419 x 178	Fabricated	Cast	SAP	Steer or Drive Axles
ES-165-7F	16.5 x 7	419 x 178	Fabricated	Forged	SAP	Trailer Axles
ES-165-7H	16.5 x 7	419 x 178	Cast	Heavy Cast	DAP	On/Off Hwy. Drive Axles
ES-165-7L	16.5 x 7	419 x 178	Fabricated	Fabricated	SAP	Steer or Drive Axles
ES-165-7M	16.5 x 7	419 x 178	Fabricated	Heavy Cast	DAP	On/Off Hwy. Drive Axles
ES-165-8L	16.5 x 8.63	419 x 219	Fabricated	Fabricated	SAP	Drive Axles
ES-165-8D	16.5 x 8.63	419 x 219	Fabricated	Cast	SAP	Drive Axles
ES-165-8F	16.5 x 8.63	419 x 219	Fabricated	Forged	SAP	Trailer Axles
ES-165-8L	16.5 x 8.63	419 x 219	Fabricated	Forged	SAP	Trailer Axles
165 XL Cast	16.5 x 10	419 x 254	Cast	Cast	DAP	Drive Transit

Table 1. Bendix Brake Models and Specifications

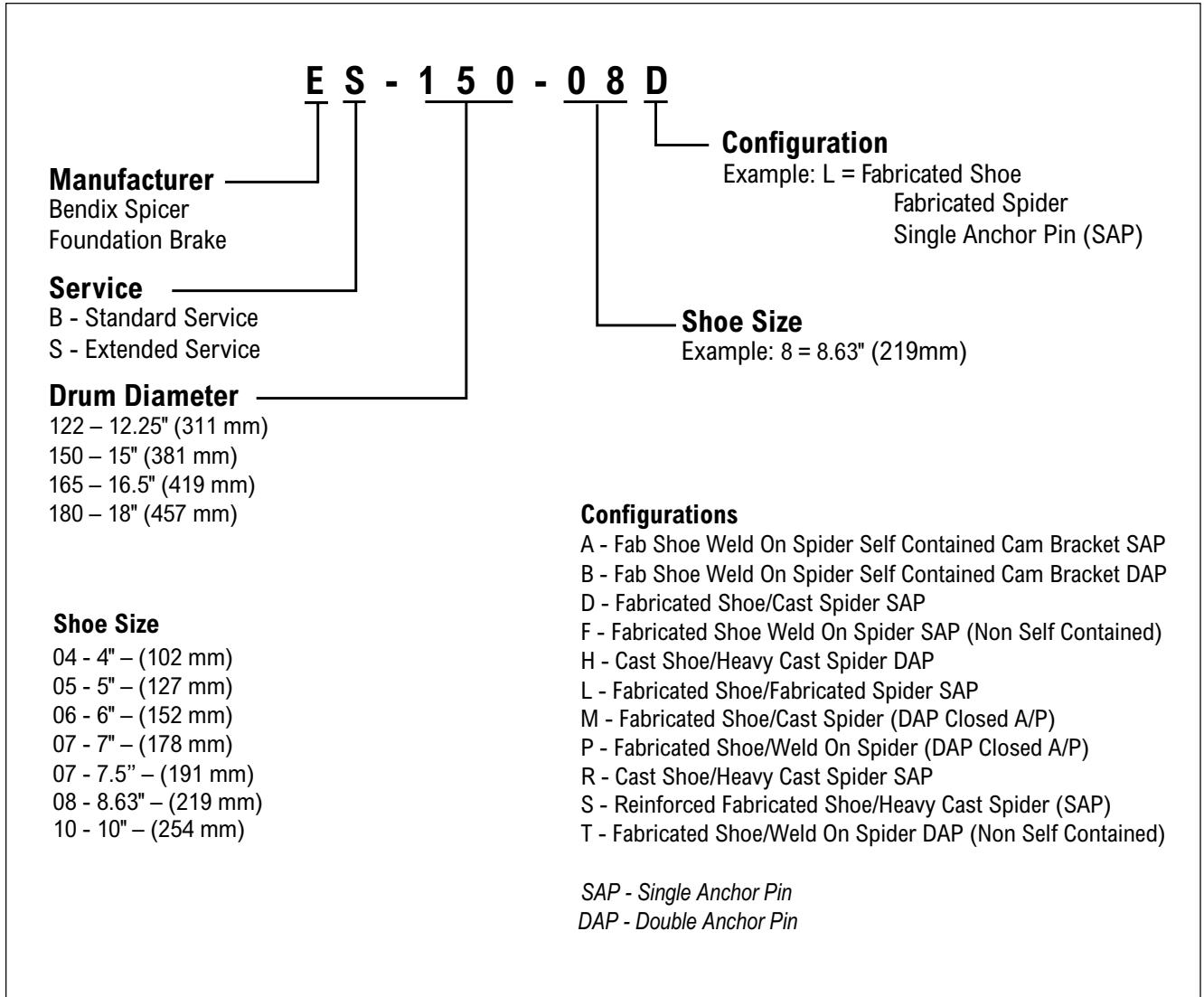

Figure 2. Bendix Brake Model Identification



Parts Nomenclature

General parts nomenclature for Bendix brake models are identified in Figure 3. Variations in shoe hold-down springs and guides are

also identified. Specific parts nomenclature for specific Bendix brake models are provided in Figure 4.

ES-150-4L Brake

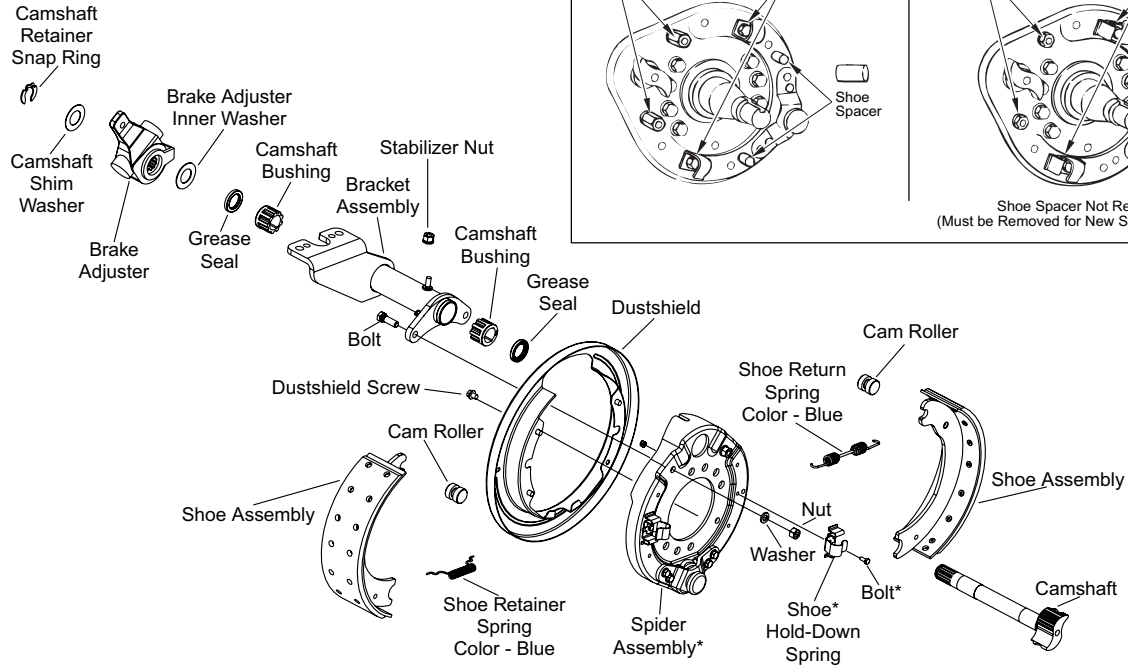

*Shoe Hold-Down Spring and Guide Variation

Shoe Hold-Down Spring and Guide Variation

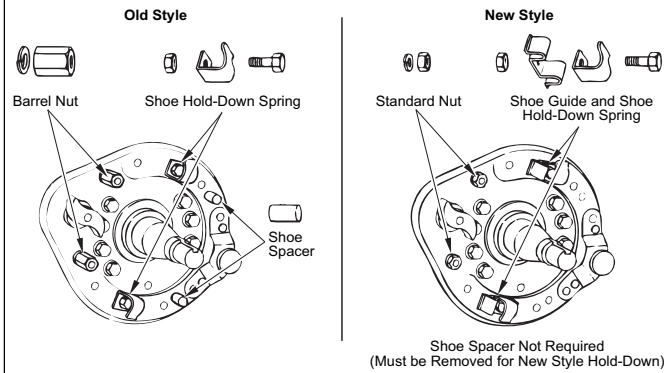

ES-150-4D Brake

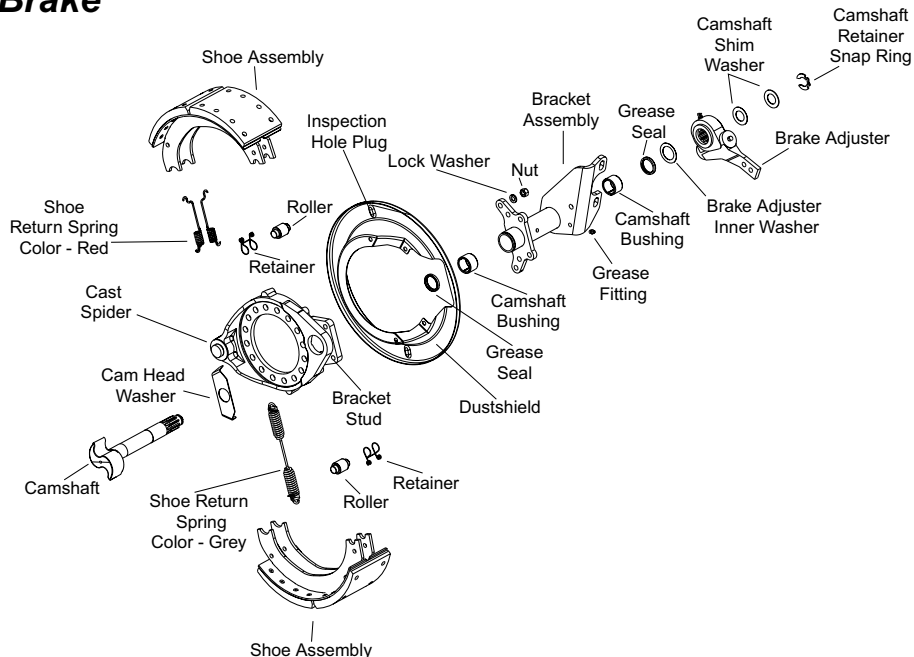
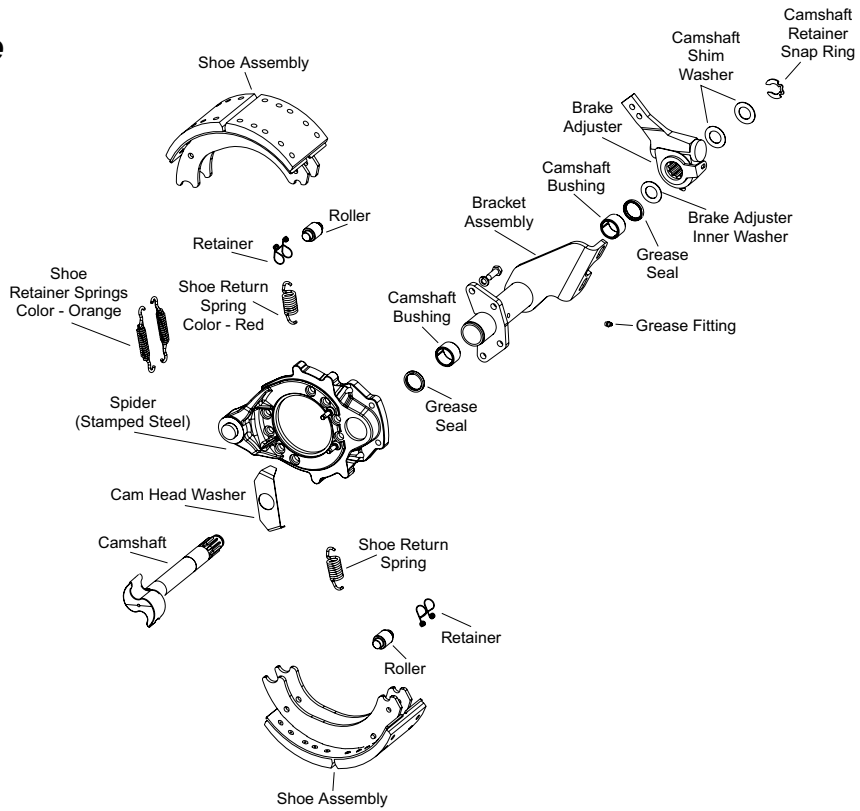

Figure 3. Brake Part Nomenclature, General

**ES-150-6D
Steer Brake**



**ES-150-8D and
ES-150-8F
Drive & Trailer
Brake**

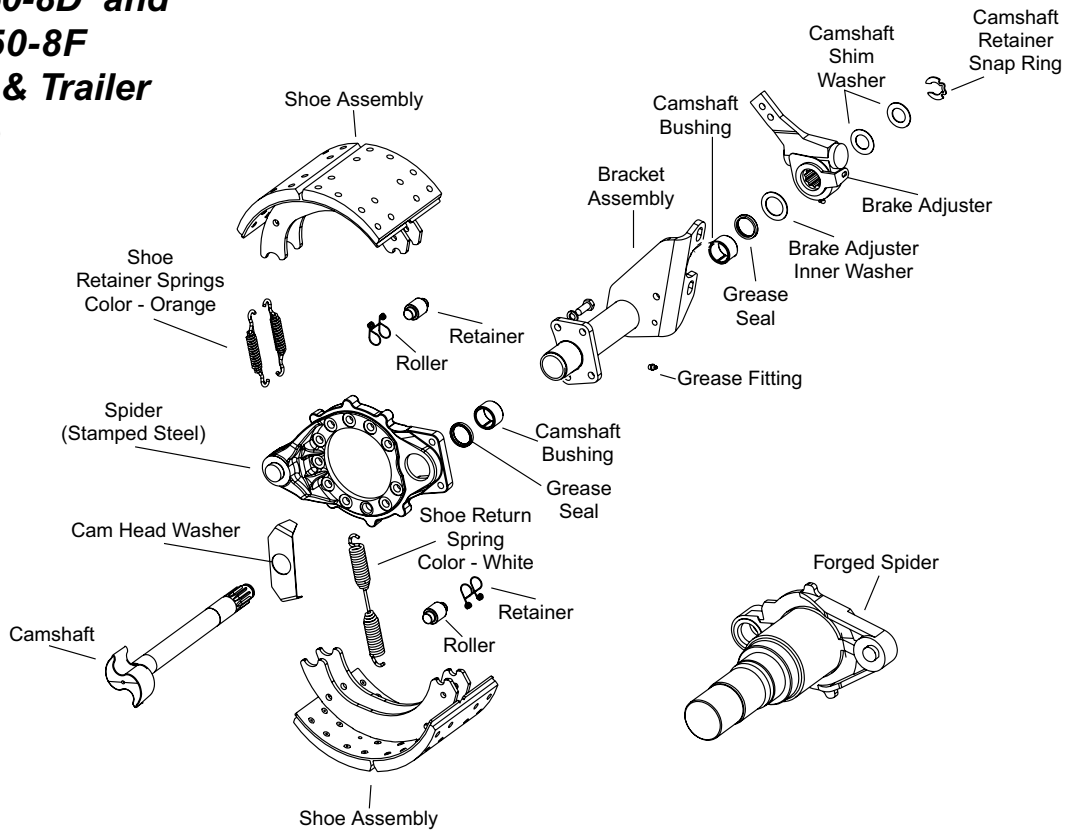
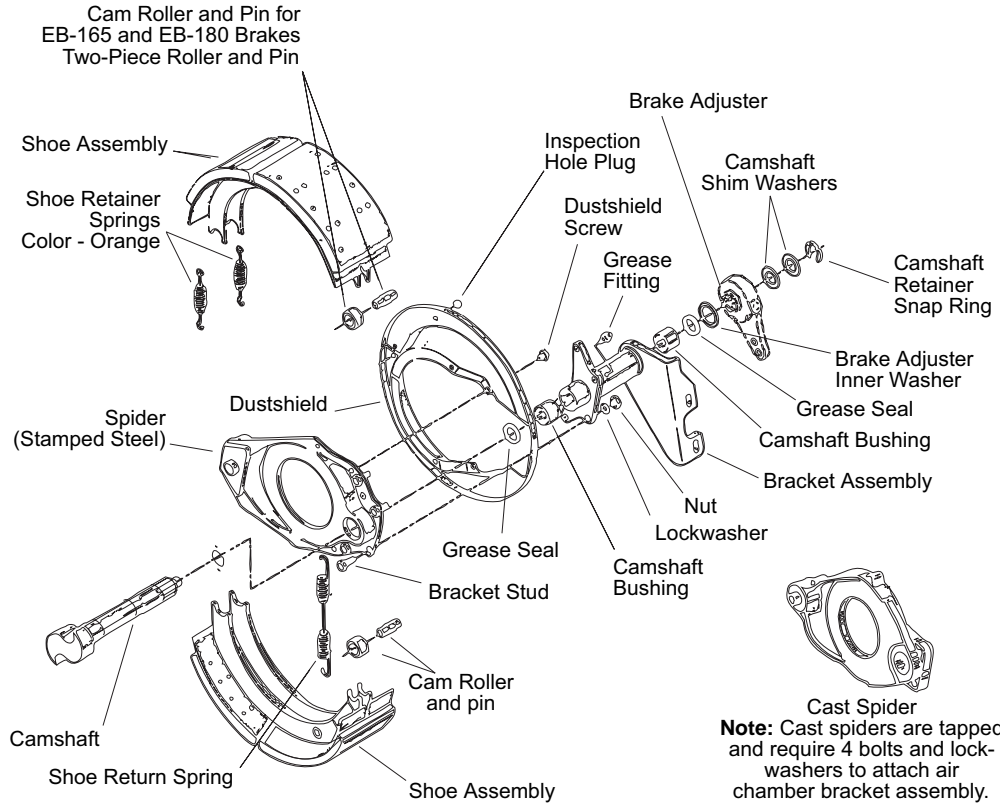

Figure 4. Brake Model Part Nomenclature



Parts Nomenclature

Brake Model
EB-165-5D
EB-165-5L
EB-165-6D
EB-165-6F
EB-165-7D
EB-165-7F
EB-165-7L



Brake Model
ES-165-5D
ES-165-5L
ES-165-6D
ES-165-6F
ES-165-7D
ES-165-7F
ES-165-7L

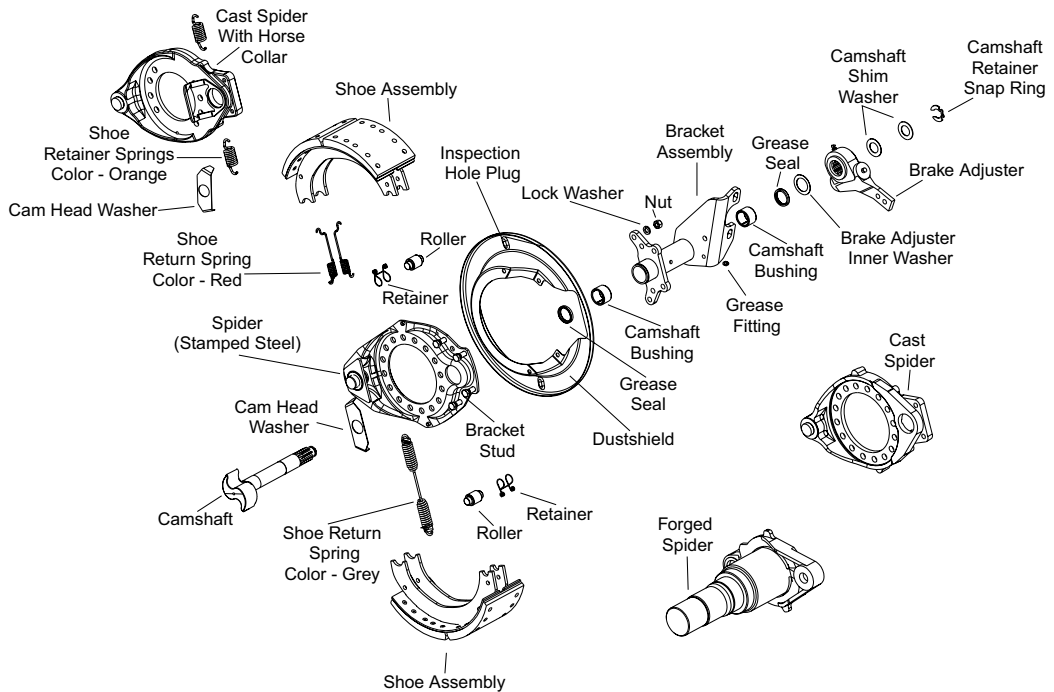
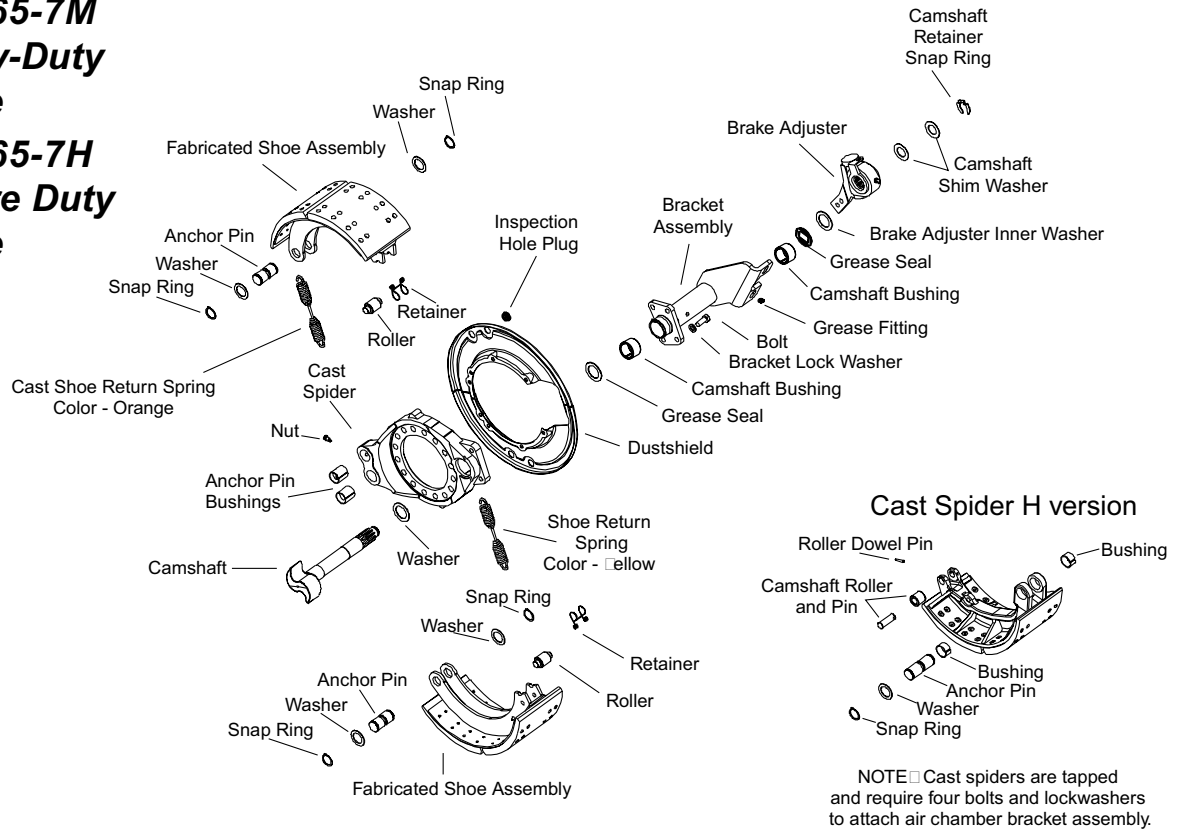
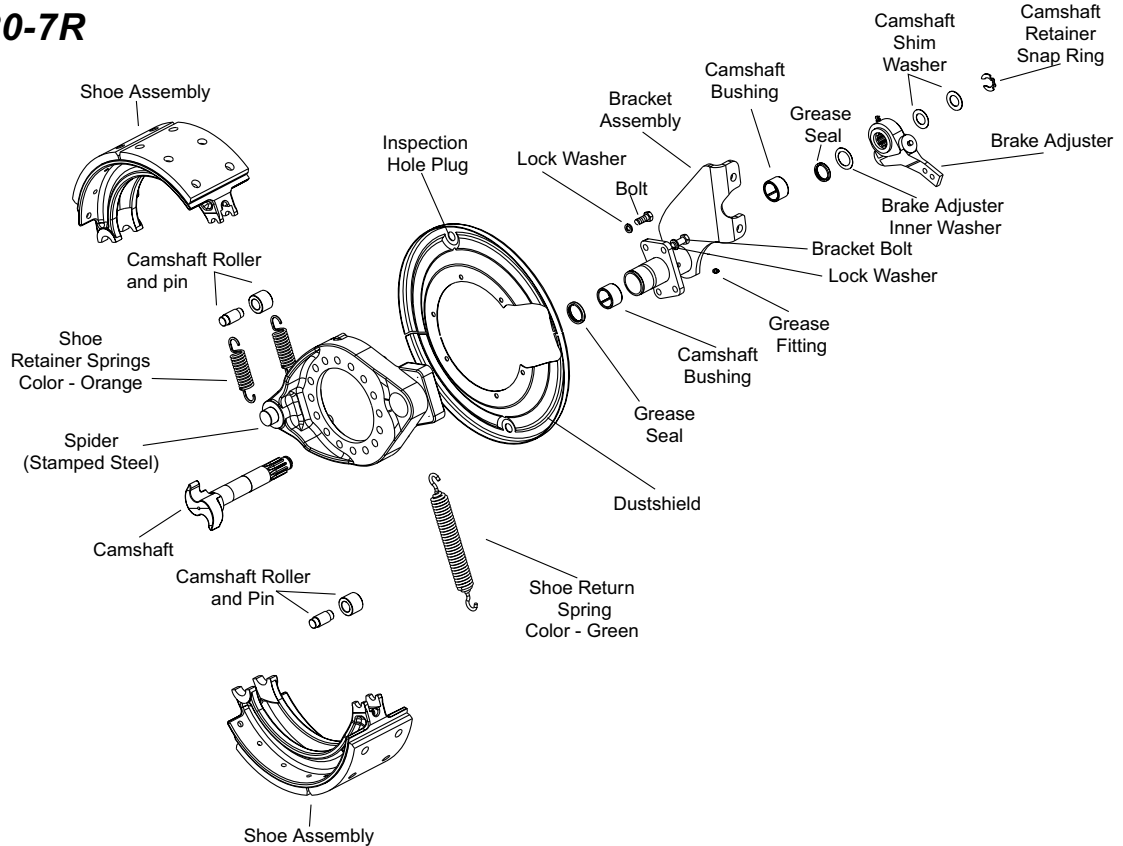

Figure 4. Brake Model Part Nomenclature, Continued

**ES-165-7M
Heavy-Duty
Brake**
**ES-165-7H
Severe Duty
Brake**



**ES-180-7R
Brake**





Parts Nomenclature

Model ES-165 and EB-165 Interchangeability

Brake parts for the Extended Service Brake (Model ES-165) are unique and must not be intermixed with Standard Brake parts (Model EB-165) unless otherwise instructed. These parts consist of the camshaft, camshaft washer, return spring, cam roller and shoe/lining assembly. Any attempt to operate the brake with other than its intended parts may result in unsatisfactory performance.

“On-Road” Repair: If a vehicle should need “On-Road” repair and ES™ Brake hardware is not available, it is possible to retrofit the brake with Standard Brake parts in order to return the vehicle to service. These parts consist of the Standard shoe/lining assembly, cam roller, pin and return spring. The retaining springs and camshaft with cam washer will work in this situation and do not need to be replaced.

EB™ Roller and ES™ Cam Interchangeability

The EB™ Roller and the ES™ Cam are compatible and can be used together. Figure 5 illustrates the proper fit of an EB™ Roller to an ES™ Cam. As shown, the contact pattern is at two points and the two parts will function satisfactorily with this fit.

NOTE: The ES™ Roller and EB™ Cam are not compatible and should not be used together.

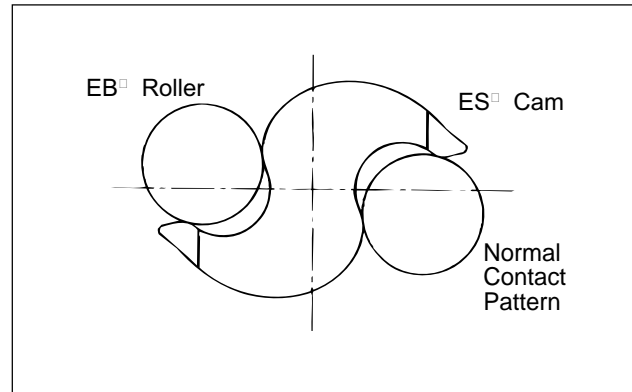

Figure 5. EB™ Roller and ES™ Cam Contact Pattern

Bendix brake model parts identification for shoes, return springs, spiders and camshafts are identified in Figure 6.

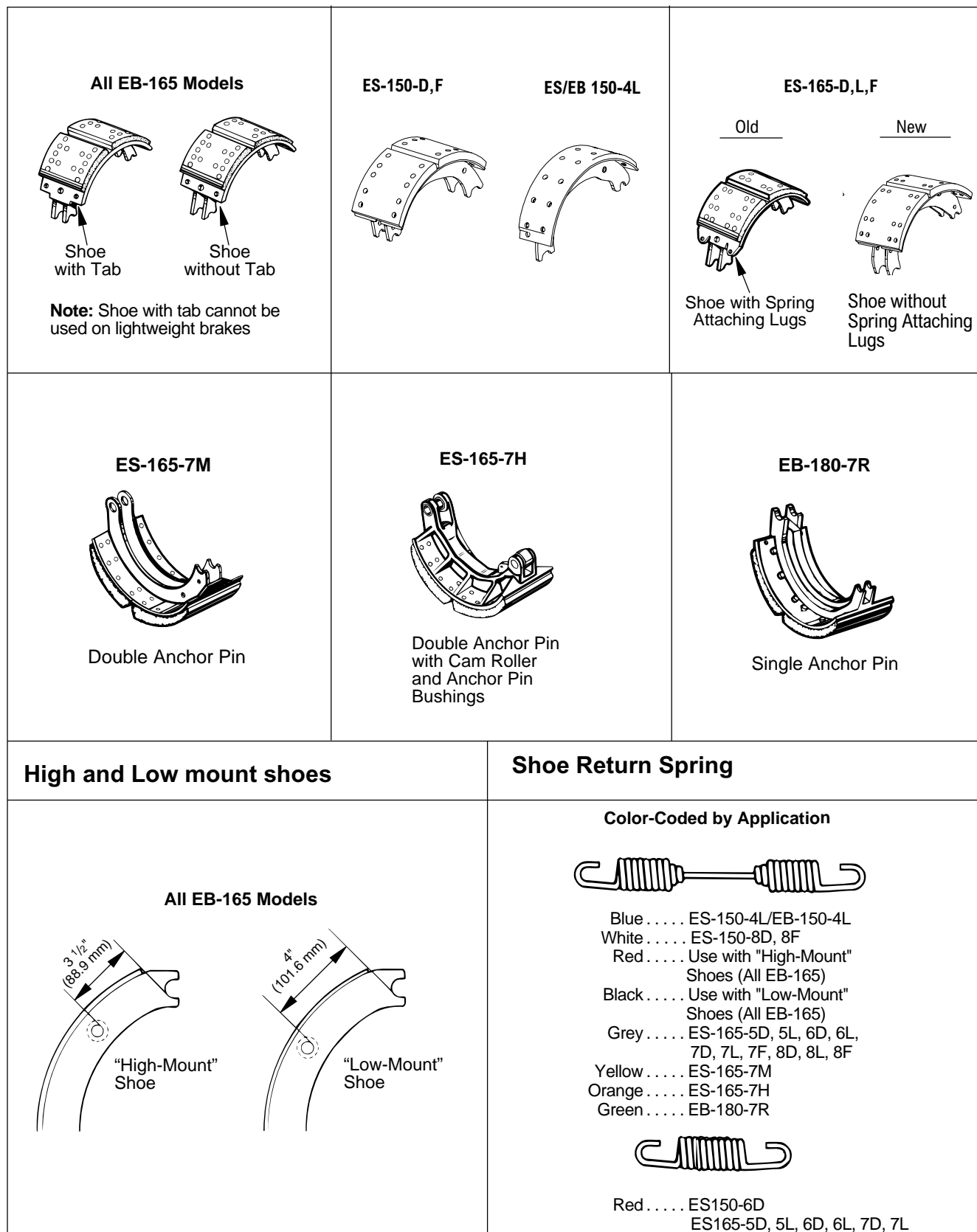
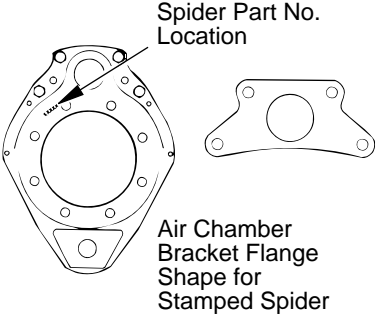
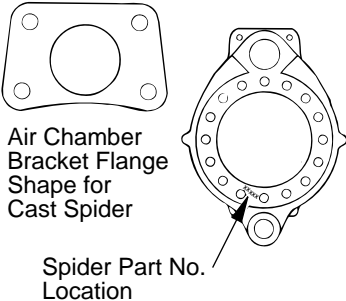
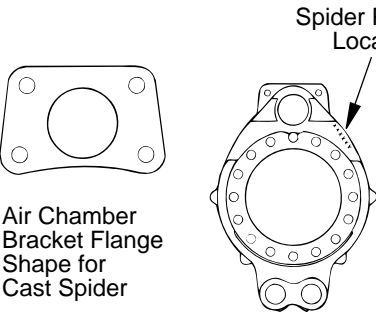
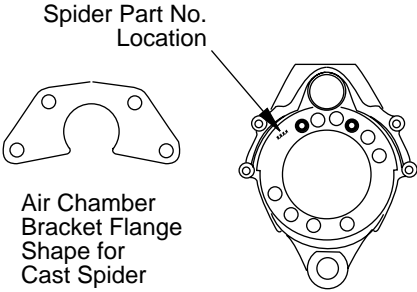
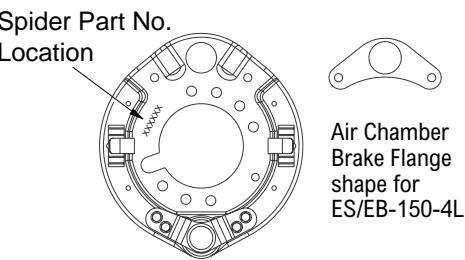
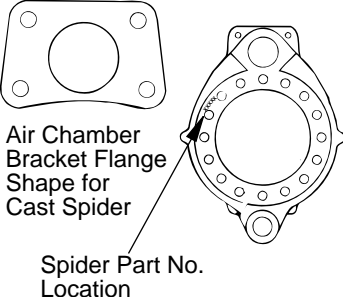

Figure 6. Parts Identification



Brake Spiders

<p>Lightweight Stamped Spider Single Anchor Pin</p> <p>Spider Part No. Location</p>  <p>Air Chamber Bracket Flange Shape for Stamped Spider</p>	<p>Cast Spider Single Anchor Pin</p>  <p>Air Chamber Bracket Flange Shape for Cast Spider</p> <p>Spider Part No. Location</p>
<p>Cast Spider Double Anchor Pin</p> <p>Spider Part No. Location</p>  <p>Air Chamber Bracket Flange Shape for Cast Spider</p>	<p>Reduced Envelope Steer Brake Cast Spider Single Anchor Pin</p> <p>Spider Part No. Location</p>  <p>Air Chamber Bracket Flange Shape for Cast Spider</p>
<p>Stamped Spider ES/EB-150-4L</p> <p>Spider Part No. Location</p>  <p>Air Chamber Brake Flange shape for ES/EB-150-4L</p>	<p>Reduced Envelope Drive Brake Cast Spider Single Anchor Pin</p>  <p>Air Chamber Bracket Flange Shape for Cast Spider</p> <p>Spider Part No. Location</p>

Camshafts

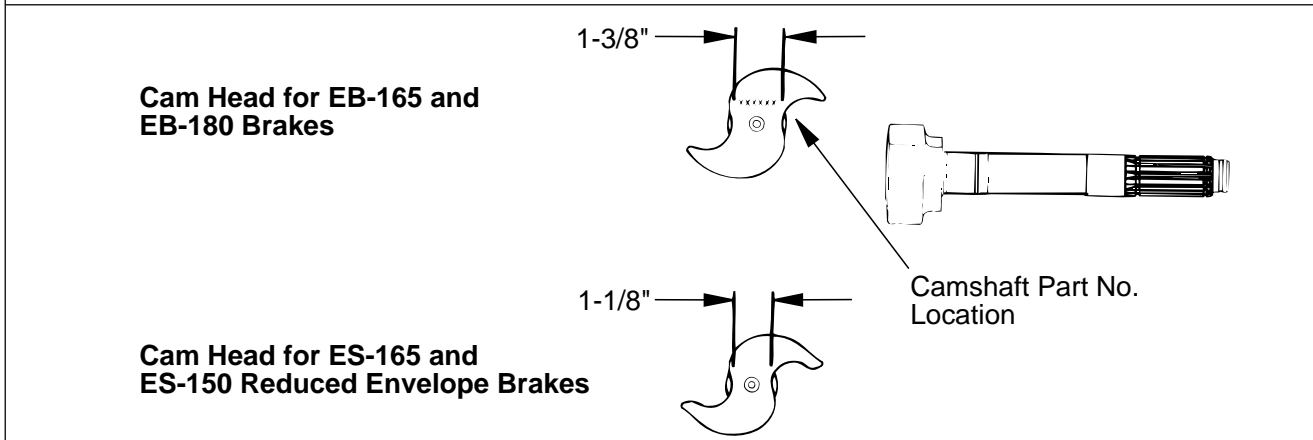

Figure 6. Parts Identification, Continued

Maintenance and Adjustment

Due to the importance of a well-maintained brake system, the inspections and maintenance listed below must be accomplished by commercial vehicle operators at the intervals suggested. Since driver technique and vehicle use affect the rate of brake component wear, it may be appropriate to increase the frequency of the following inspections to fit individual needs based upon past experience.

Brake Maintenance Preliminary Steps

Prior to performing any maintenance requiring removal of the tire and wheel, the following preliminary steps must be taken to ensure your safety. Refer to Figure 7.

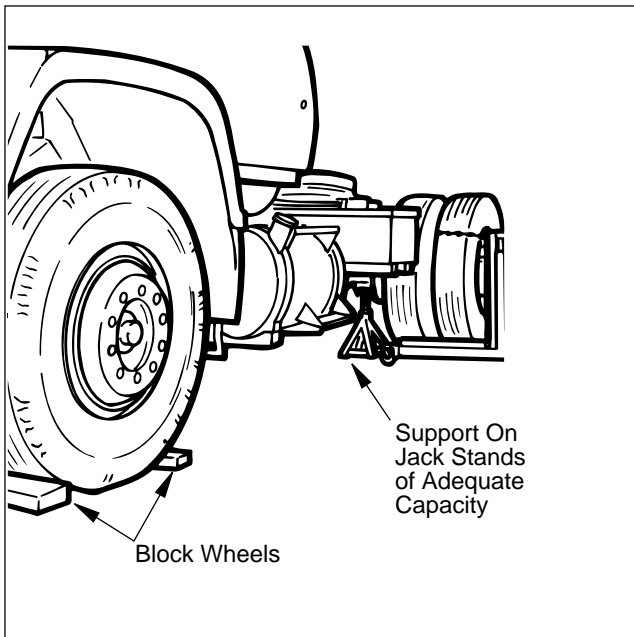

Figure 7. Vehicle Maintenance Support

1. Set parking brake and block wheels to prevent vehicle movement.
2. Raise drive axle with a jack and support on suitable stands.

! WARNING: Never work under a vehicle supported by a jack.

3. Cage spring-type brake chamber following vehicle manufacturer's instructions.

Brake Adjustment - Manual Brake Adjuster

NOTE: An assistant is required to make a brake adjustment.

! WARNING: Block all wheels before beginning this adjustment procedure.

To determine whether Bendix Brakes require adjustment, applied stroke is measured and compared to the maximum value for the air chamber size in use on the vehicle.

1. Perform "Brake Maintenance Preliminary Steps" described earlier.
2. With air chamber pushrod fully retracted, measure distance from face of air chamber to centerline of clevis pin hole. Refer to Figure 8. If the measurement is not within ranges shown in Table 2, reposition clevis. Remeasure the distance and repeat until within range. Record exact measured distance as dimension "A".

Distance: Clevis Pin Hole Centerline to Air Chamber Face	
All brakes (except Mack and Trailer Axle)	2-5/8" ± 1/16" (66.7 ± 1.59 mm)
Mack brakes	4-3/8" ± 1/16" (111.1 ± 1.59 mm)
Trailer Axle brakes	6-1/2" ± 1/8" (165.1 ± 3.175 mm)

Table 2. Distance Range

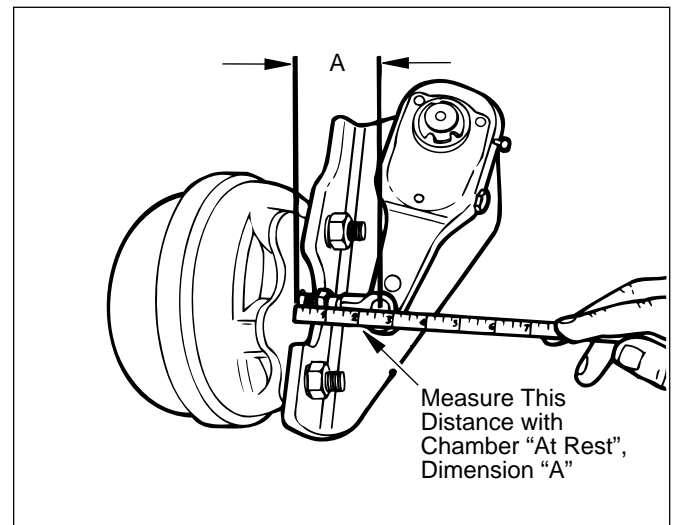

Figure 8. Measurement, At Rest



Maintenance and Adjustment

3. Apply and hold an 80 psi brake application, and again measure from face of air chamber to clevis pin centerline. Refer to Figure 9. Record distance as dimension "B".

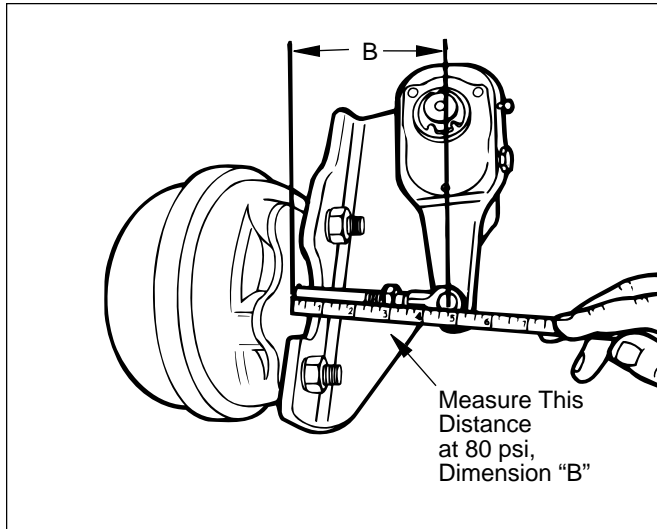

Figure 9. Measurement, 80 psi Applied

4. Subtract dimension "A" from "B". The difference is applied stroke. Compare applied stroke to maximum value in Table 3. If applied stroke equals or exceeds maximum applied stroke shown, adjust brakes. If less than the maximum, no adjustment is required and you may perform **Brake Operation Check**.

80 - 90 PSI		
Air Chamber Size	Maximum Applied Stroke	Desired Free Stroke
Type 30" Long Stroke	2.5"	3/8" to 5/8"
Type 30"	2"	(Without Drag)
Type 24"	1-3/4"	
Type 24" (w/ 2-1/2" extended stroke)	2"	
Type 24" (w/3" extended stroke)	2.5"	
Type 20" and 16"	1-3/4"	3/8" to 1/2"
Type 12"	1-3/8"	3/8" to 1/2"

Table 3. Stroke Values

NOTE: If adjustment is necessary, Bendix Brakes are adjusted to achieve proper free stroke. The difference between free stroke and applied stroke is merely the method used to move the brake adjuster from rest. Applied stroke uses an 80 psi brake application; free stroke is measured using a lever to move the brake adjuster until the brake shoes contact the drum. If applied stroke exceeded the maximum and adjustment is necessary, adjust the brakes as described in steps 5 through 8 below.

5. Take "A" dimension exactly as before. Take "B" measurement using a lever to move brake adjuster as shown until the shoes contact drum. Refer to Figure 10. The result of "B" - "A" is brake free stroke. Adjust free stroke to within range specified in Table 3.

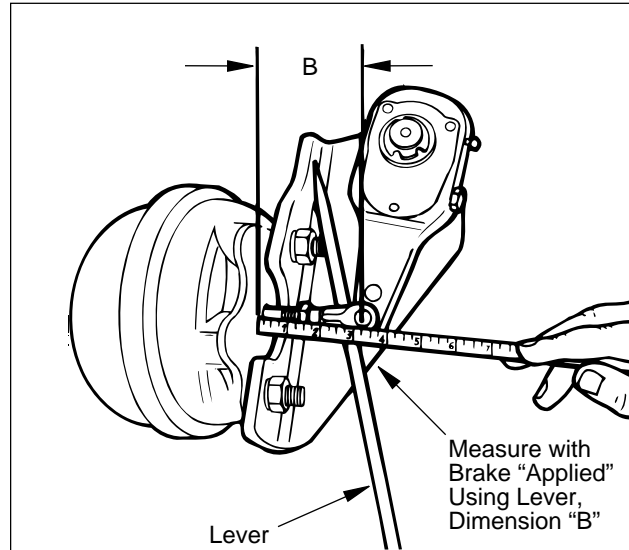

Figure 10. Measurement, Brake Applied

6. To adjust free stroke, depress locking sleeve on brake adjuster adjustment nut and turn in direction required. Recheck free stroke to verify it is within range. Make sure sleeve is "locked" when adjustment is completed.
7. Verify that brakes are not dragging by spinning wheels by hand or tapping drum lightly with a hammer and listening for a sharp ringing sound.
8. Perform **Brake Operation Check**, to verify proper operation of brakes before releasing vehicle for service.

Brake Adjustment - Automatic Slack Adjuster

NOTE: A properly working Automatic Slack Adjuster does not require manual adjustment while in service. The manual adjuster hex is intended for use during adjuster installation and brake overhaul.

WARNING: Automatic slack adjusters must never be repeatedly adjusted to correct excessive in service pushrod stroke, because this condition indicates that a problem exists with the automatic adjuster, with the installation of the adjuster or with related foundation brake components which manual adjustment will not correct.

1. Brake adjustment for automatic slack adjusters is the same as for manual brake adjusters.
2. Refer to the Automatic Slack Adjuster Manufacturer's Instructions for proper installation.

Brake Operation Check

NOTE: An assistant is required to make a thorough brake operation check.

1. Apply brakes to 80 psi and hold. Check all air line fittings and air chambers for leakage.
2. Apply and release brakes while observing operation of brake adjusters on each axle. As brakes are applied and released, brake adjusters should move in unison visually.
3. Investigate source and make corrections for any discrepancies found in Steps 1 and 2.

4. Drive vehicle at low speeds in a safe area and make several brake applications to verify safe operation and absence of pulling, grabbing, or noise. If any of these are noted, investigate and repair prior to releasing vehicle for service.



CAUTION: Never release a vehicle for service if any brake discrepancy - no matter how minor - is evident.

Lubrication

When servicing brakes or replacing components, lubricate per guidelines listed in Lubrication Table below.

Lubricate the following components with grease specified in table:

- One-piece Roller —lubricate shoe roller recess.
- Two-piece Roller—lubricate shoe roller I.D.
- Roller and anchor pin recesses of each shoe on ES & ED 150-4L models

Do Not Lubricate The Following:

- Cam head surface or related parts that contact cam head surface. For efficient operation, the cam head surface must remain free of oil, grease or other contaminants.

Note: When lubricating the camshaft bracket, lubricate until grease comes out at the brake adjuster end.

The seal is installed at this end with the air side in so that grease purges out.



CAUTION: Do not use moly-disulfide loaded grease or oil because this may shorten service life.

Important: In no case should the lubrication interval exceed the published intervals in table below.

Component	Lubrication Interval	Type of Lubricant
Standard	Every 50,000 miles or every 3 months	Standard Chassis Grease
LMS-Low Lube	Every 250,000 miles or once a year*	Mobilith SHC-460 Synthetic
LMS-Lube Free	None*	Mobilith SHC-PM Synthetic

Table 4. Lubrication Intervals

Note: The Bendix LMS-Low Lube brake uses a special “button head” grease fitting. This helps identify the system as an LMS Brake Package and also indicates that system should be lubricated with a Bendix approved synthetic lubricant.

The Bendix LMS-Lube Free brake is lubricated at the factory with Mobilith SCH-PM synthetic grease and does not require lubrication at service intervals. There is no grease fitting on the LMS lube free components.

Brake Adjuster Lubrication: Pressure lubricate according to manufacturer’s instructions.



Periodic Inspections

The component inspections discussed below are general in nature. More detailed component inspections are normally done at overhaul. For more specific guidelines, refer to the appropriate inspection instructions in **Brake Overhaul**.

Visual Inspection

A thorough visual inspection for brake wear, loose fasteners, broken parts and/or obvious damage should be made each time the brake is being serviced or the wheel and drum have been removed. **In no case should the visual inspection interval exceed 3 months of service.**

Lining Inspection

A visual check of lining thickness and condition should be made each time the vehicle is being serviced in the maintenance shop. **In no case should the lining thickness/condition inspection interval exceed 3 months of service.**

Brake Adjustment

Brake Adjustment should be checked (and adjusted if necessary) WEEKLY or any time applied stroke exceeds the maximums shown in Periodic Maintenance: Brake Adjustment - Manual Brake Adjuster.

Brake Operation Check

A complete operation check of the braking system should be made following the instructions in **Brake Operation Check**, after any brake service. **In no case should the operation check interval exceed 3 months of service.**

Service Intervals

Brake Reline

A brake reline should be done any time the lining thickness or condition indicates the need.

Camshaft Radial Play

Camshaft radial play should be checked with a dial indicator any time the brake shoes have been removed from the vehicle to assess the condition of the camshaft bushings. Refer to **Camshaft Inspection**.

Camshaft Axial Play

Camshaft axial play should be checked any time the camshaft or brake adjuster has been removed from the vehicle. Refer to the axial play instructions in **Brake Adjuster Installation**, starting with Step 6.

Brake Overhaul

A complete brake overhaul following the instructions in the service manual should be accomplished at every third brake reline.

Lubrication

See **Periodic Service / Lubrication** for detailed lube instructions and intervals.

A complete brake overhaul consists of:

- complete disassembly
- cleaning
- inspection
- repair and replacement of components
- assembly
- brake operation check

Detailed instructions for each of these steps are listed on the following pages in the order in which they would normally be encountered during a typical brake overhaul.

! WARNING: The long-term effects of non-asbestos fibers have not been determined. Therefore, precautions should be used when handling these materials.
See General Information / Lining Material Warning

Drum Removal

1. Perform “**Brake Maintenance Preliminary Steps**”.
2. While depressing locking sleeve, back off brake adjuster adjustment nut on manual brake adjusters. Refer to Figure 11. Continue turning until shoes are fully returned to released position and clear of drum. On self adjusting brake adjusters, follow manufacturer’s instructions.

NOTE: With outboard mounted drums go to step 6.

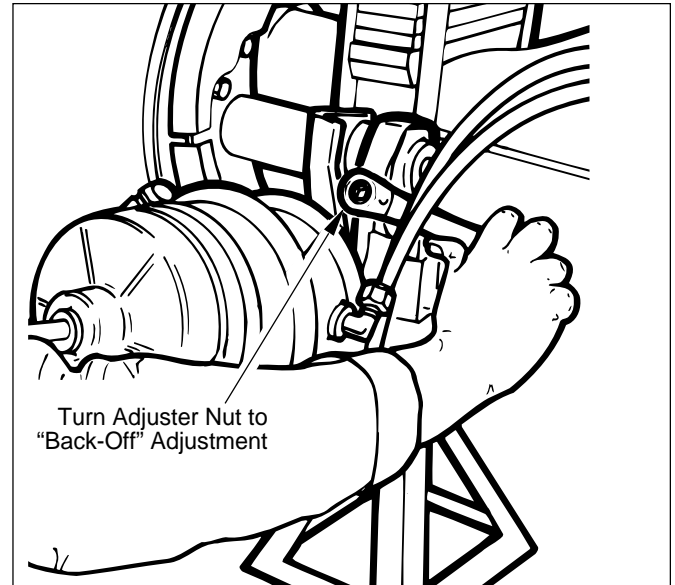

Figure 11. Brake Adjuster Adjustment

3. On drive axles, remove stud nuts and axle shafts. If used, remove lockwashers and taper dowels. If necessary, loosen dowels by holding a brass drift in the center of the shaft head and striking it a sharp blow with a hammer. On trailer and steer axles, remove hub cap.

! WARNING: Do not strike the axle shaft flange with a hammer.
Do not use chisels or wedges to loosen shaft or dowels.

4. Remove axle spindle nut(s) and washer.
5. While rocking drum, pull outboard enough to allow removal of outer wheel bearing.
6. Remove drum by pulling outboard while rocking from side to side. If shoes are not clear of drum, return to Step 2 above.

! CAUTION: If difficulty is found on removal, do not force drum.
Excessive pulling force may damage brake components.



Shoe Removal

Shoe Removal

Table 5 provides an index to the location of shoe removal procedures. Locate the brake model under service and identify the page where the appropriate shoe removal procedures are located.

Brake Model	Page Number	Brake Model	Page Number
EB-150-4L	22	EB-180-7R	20
EB-165-5D	20	ES-150-4L	22
EB-165-5L	20	ES-150-6D	20
EB-165-6D	20	ES-150-8D	20
EB-165-6L	20	ES-150-8F	20
EB-165-7D	20	ES-165-5D	20
EB-165-7L	20	ES-165-5D	20
EB-165-7F	20	ES-165-5L	20
EB-165-8D	20	ES-165-6D	20
EB-165-8F	20	ES-165-6L	20
EB-165-8L	20	ES-165-7F	20
		ES-165-7H	25
		ES-165-7L	20
		ES-165-7M	23

Table 5. Shoe Removal Procedure Index

NOTE: The following procedures are divided into sections, identified by brake model numbers.

Shoe Removal

EB models (except EB-150-4L)/ES-165-5D,L / ES-165-6D,L / ES-165-7D, F, L / ES-150-8D, F / ES-150-4D/ES-150-6D/ES-165-8D,F,L

1. Perform steps in **Removal/Disassembly: Drum Removal**.
2. **ES-165-5,6,7,8,D,L,F, ES-150-4D, ES-150-8D, F & 6D ONLY:**
Pry roller retainer coiled loops out of both shoe web holes as shown in Figure 12. Pivot roller retainer to swing loops clear of shoe webs.

NOTE: EB models do not have roller retainers.

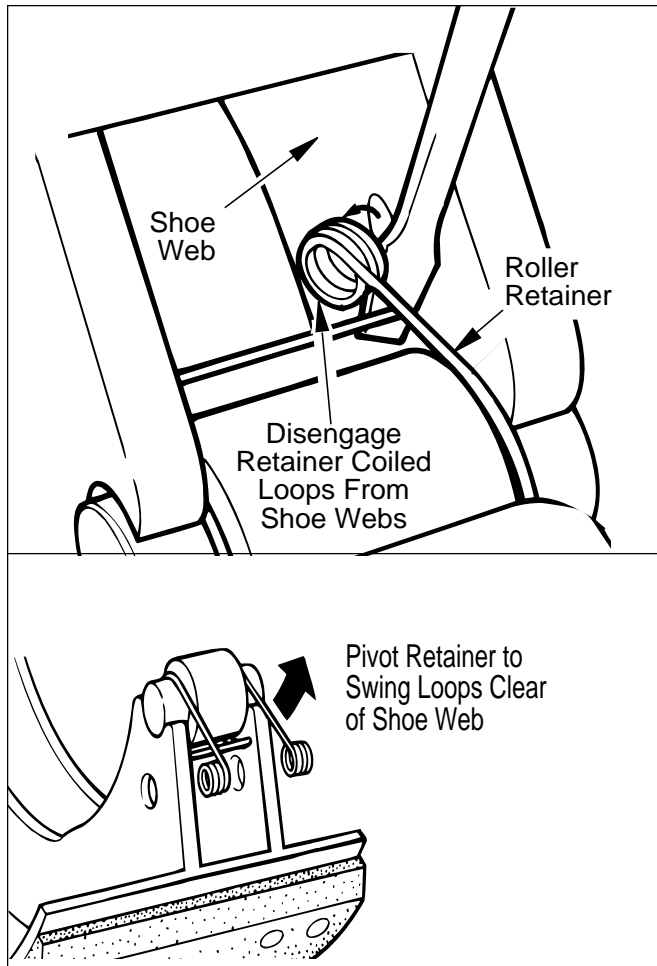

Figure 12. Roller Retainer Removal



WARNING: The long term effects of non-asbestos fibers have not been determined. Therefore, precautions should be used when handling these materials.

See General Information / Lining Material Warning

3. Using a large screwdriver or lever, lift upper shoe to stretch return spring as shown in Figure 13.

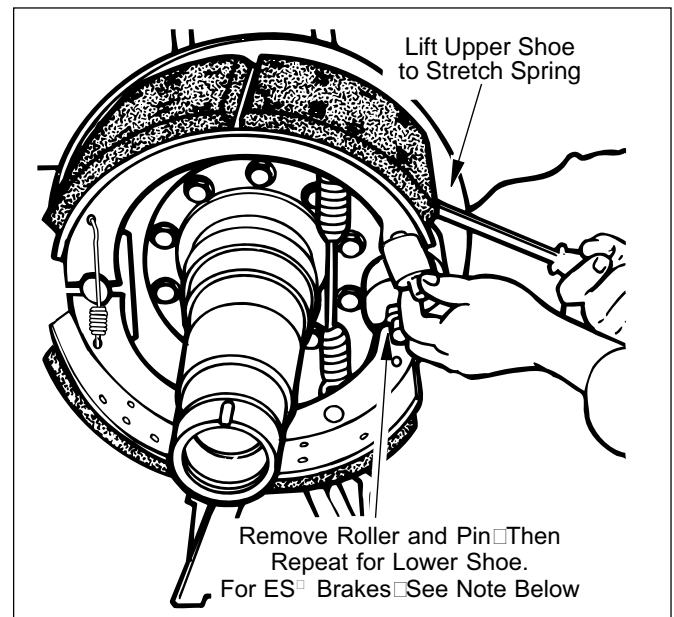

Figure 13. Upper Cam Roller and Pin Removal

4. Remove upper cam roller and pin.
NOTE: ES-165-5,6,7,8D, L, F, ES-150-4D, ES-150-8D, F & 6D ONLY: Remove roller and roller retainer as a unit.
5. Repeat Steps 2 through 4 to remove lower shoe roller and pin.

NOTE: Bendix recommends the use of a suitable brake tool when removing rollers and return springs.



Shoe Removal

6. Push cam end of both shoes toward cam and unhook shoe return spring. Remove and discard spring.

NOTE: To remove return spring, position a lever or suitable tool with notch to engage spring rod. Refer to Figure 14. Apply downward force to stretch spring, allowing removal of upper spring hook. Remove and discard spring.

7. Rotate both shoes around anchor pin and remove from vehicle. Refer to Figure 15.

8. Clean and inspect remaining parts as outlined in removal/disassembly section of this manual.

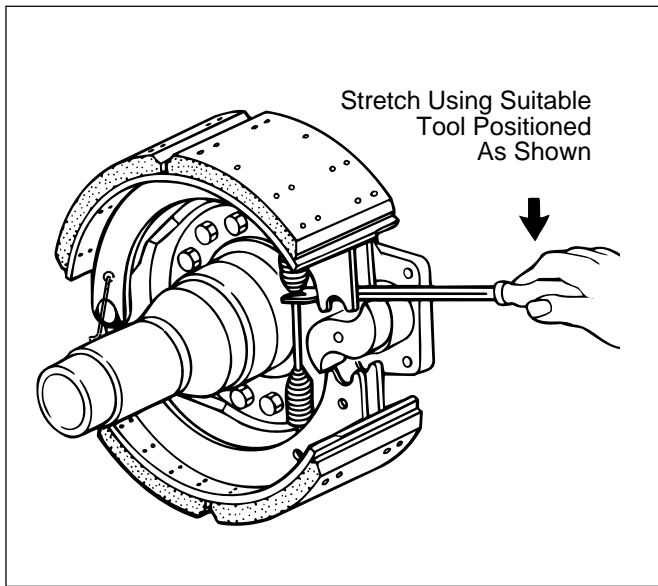

Figure 14. ES-165-7D, L, F Shoe Removal

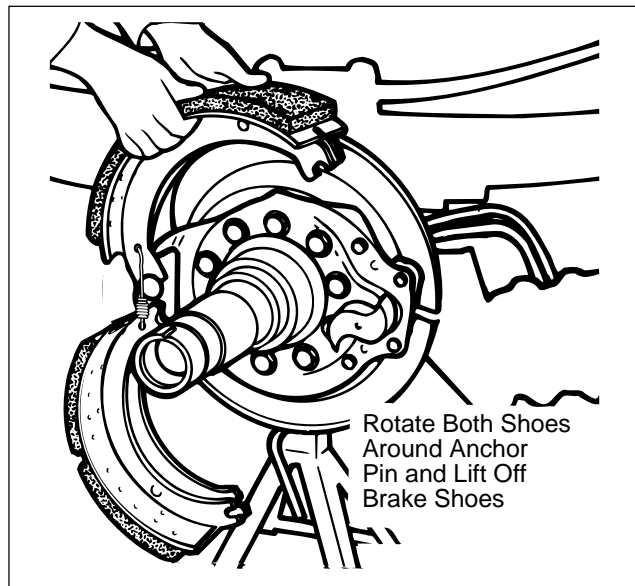

Figure 15. Shoe Removal

NOTE: ES-165-5,6,7L,D/ES-150-6D steer axle brakes may use two return springs with a horse collar or dual spring post. To remove return springs, position a lever or suitable tool with notch to engage spring. Return to Figure 14. Apply downward force to stretch upper spring, allowing removal of upper spring hook. Remove and discard. Repeat procedure for lower spring.

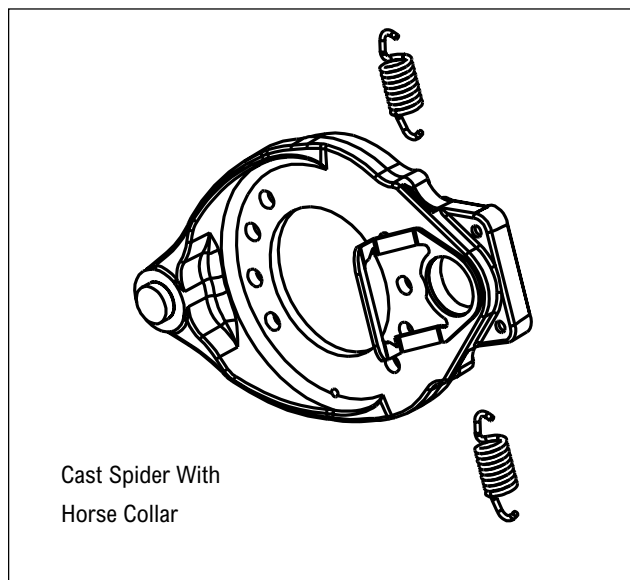

Figure 15B. Cast Spider With Horse Collar

ES-150-4L and EB-150-4L Brakes

1. Perform steps in removal/disassembly : drum removal
2. Using a large screwdriver or lever, lift upper shoe to stretch return spring.
3. Remove upper roller.
4. Repeat steps 2 through 3 to remove lower roller.
5. Stretch shoe return spring and unhook it from upper shoe web.
Refer to Figure 16.

! WARNING: The long term effects of non-asbestos fibers, have not been determined. Therefore, precautions should be used when handling these materials.

See General Information / Lining Material Warning

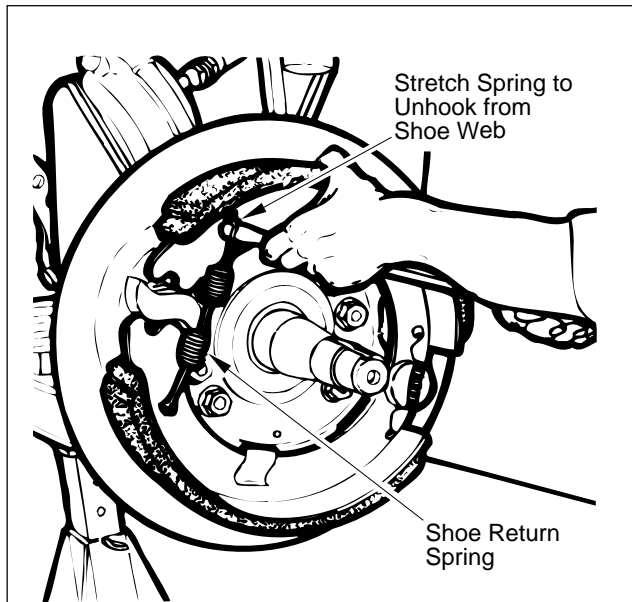

Figure 16. Shoe Return Spring Removal

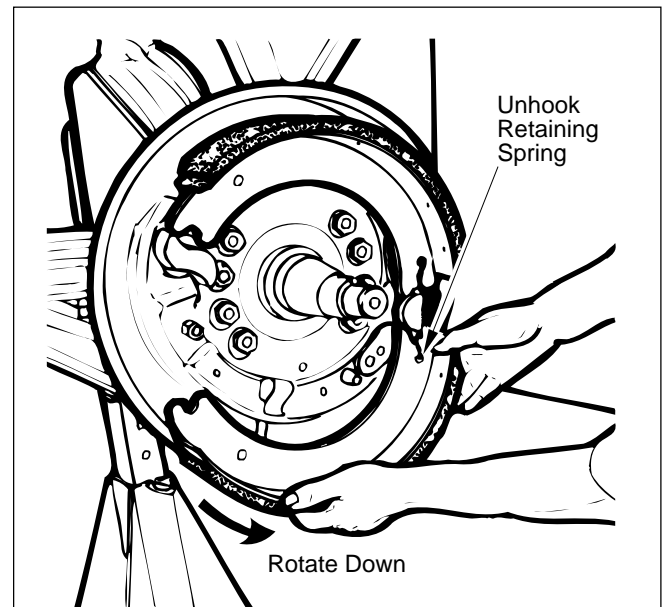

Figure 17. Lower Shoe Removal

6. Rotate shoe downward and turn to allow disengagement of shoe retaining spring from lower shoe web. Refer to Figure 17.
7. Rotate upper shoe upward and remove shoe and shoe retaining spring.
8. **Clean** and inspect remaining brake parts as outlined in **Removal/Disassembly** section of this manual.



Shoe Removal

ES-165-7M Heavy-Duty Brake

! WARNING: The long term effects of non-asbestos fibers, have not been determined. Therefore, precautions should be used when handling these materials.

See **General Information / Lining Material Warning**

1. Perform steps necessary for drum removal. See **Removal / Disassembly - Drum Removal**.
2. Remove cap screws and dustshield, if applicable.
3. Pry roller retainer coiled loops out of both shoe web holes as shown in Figure 18. Pivot roller retainer to swing loops clear of shoe webs.

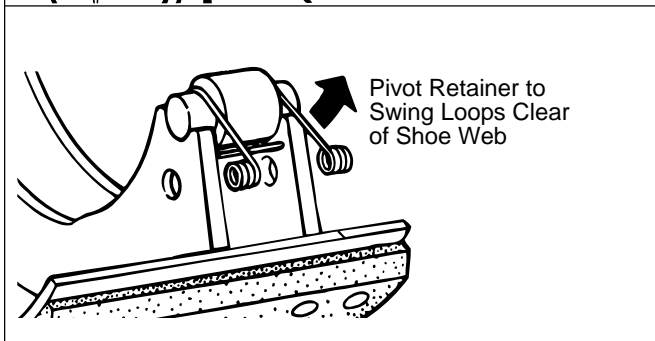
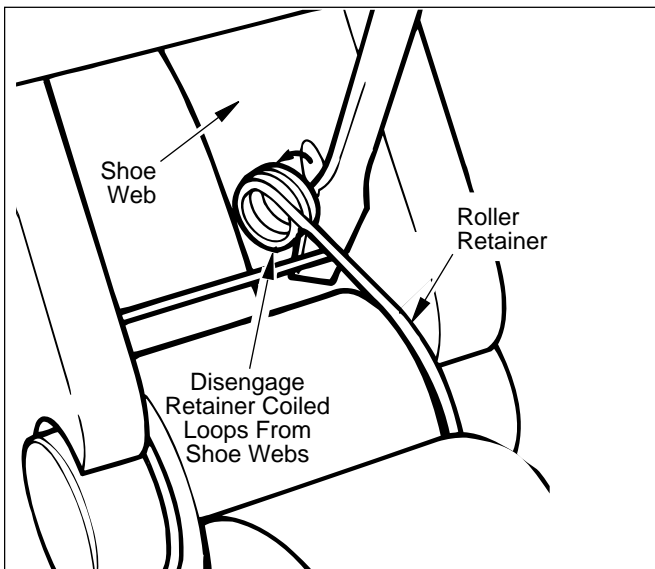

Figure 18. Retainer Loop Removal

4. Using a lever or large screwdriver, lift upper shoe to remove roller and retainer as a unit. Refer to Figure 19.

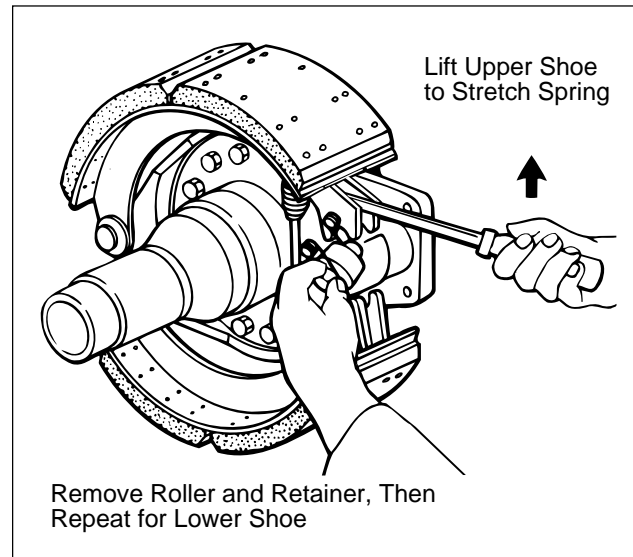

Figure 19. Roller and Retainer Removal

5. Repeat Steps 3 and 4 to remove lower roller and retainer assembly.
6. To remove return spring, position a lever or suitable tool with a notch to engage spring rod. Refer to Figure 20. Apply downward force to stretch spring, allowing removal of upper spring hook. Remove and discard spring.

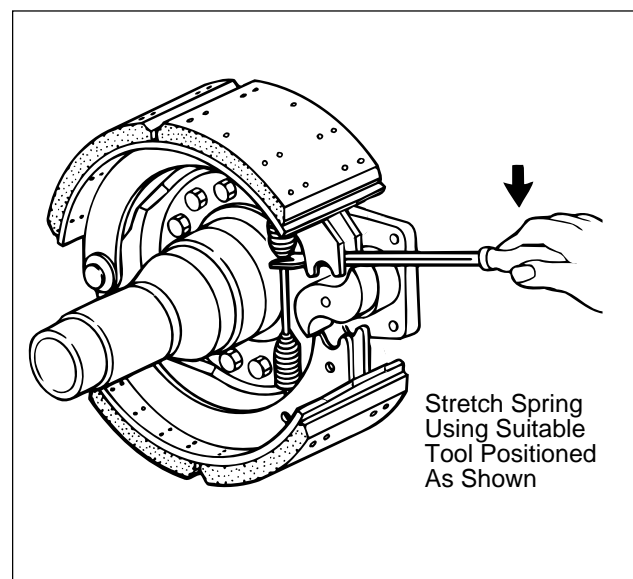

Figure 20. Return Spring Removal

ES-165-7M Heavy-Duty Brake, Continued

7. Remove retaining ring and washer from drum side of both anchor pins. Refer to Figure 21.

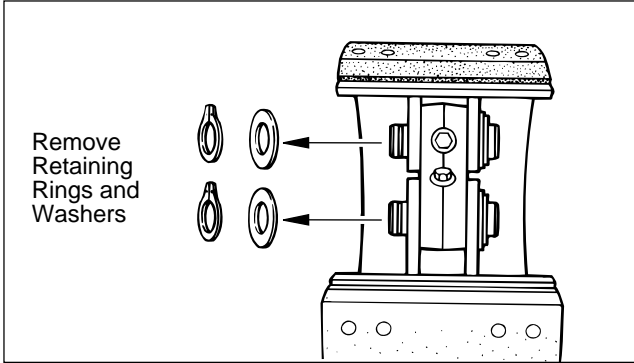

Figure 21. Retaining Ring and Washer Removal

8. To allow removal of anchor pins, cut lock wire and remove cap screws from spider. Refer to Figure 22.

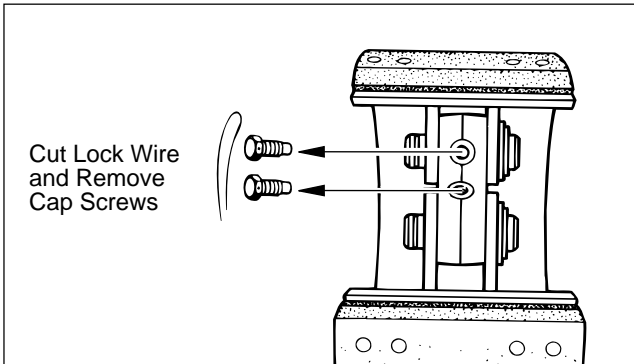

Figure 22. Cap Screw Removal

9. To remove upper and lower shoes, remove anchor pins with a brass drift or a mallet. Refer to Figure 23.

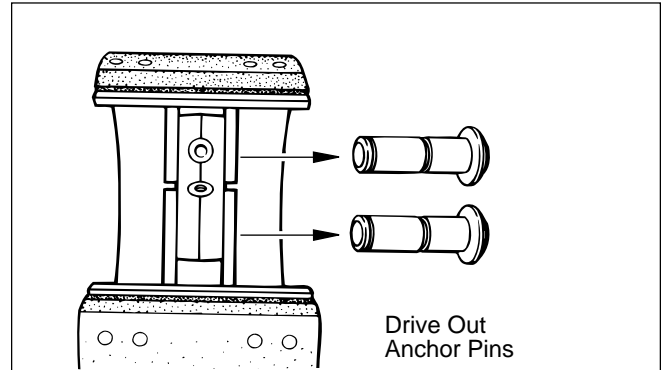

Figure 23. Anchor Pin Removal

NOTE: Inspect anchor pin and bushings. If pin was seized or bushing is grooved or worn beyond 0.031" (0.79mm), replace pin and bushing. Always replace pins and bushings with brake reline.

10. If any noted conditions are found, drive out old anchor pin bushings from spider. Refer to Figure 24.

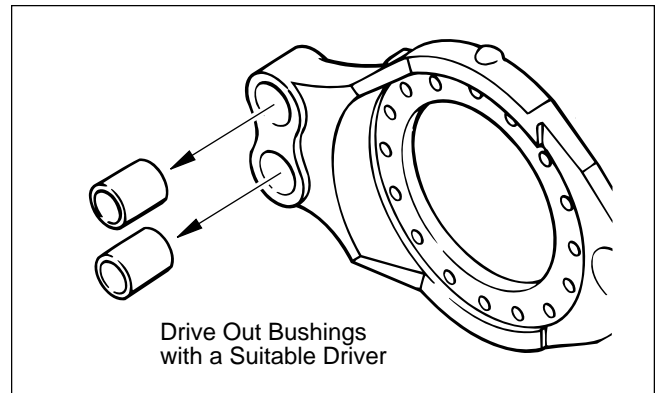

Figure 24. Anchor Pin Bushing Removal

11. Clean and inspect remaining brake parts as outlined in **Removal/Disassembly** section of this manual.



Shoe Removal

ES-165-7H Severe Duty Brake



WARNING: The long term effects of non-asbestos fibers have not been determined. Therefore, precautions should be used when handling these materials.

See **General Information / Lining Material Warning**

1. Perform steps necessary for drum removal, see **Removal Disassembly - Drum Removal**.
2. Remove cap screws and dustshield, if applicable.
3. Remove retaining ring and washer from drum side of each anchor pin. Refer to Figure 25.

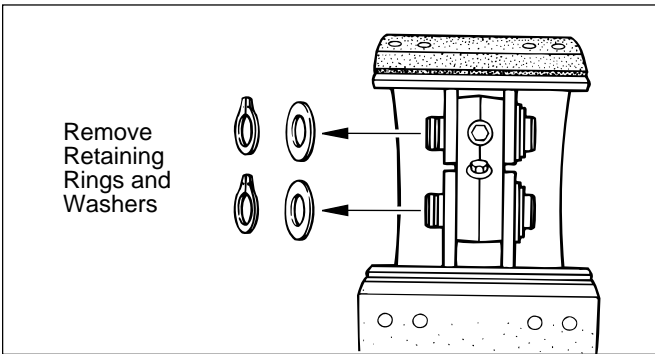

Figure 25. Retaining Ring and Washer Removal

4. To allow removal of anchor pin, cut lock wire and remove cap screws from spider. Refer to Figure 26.

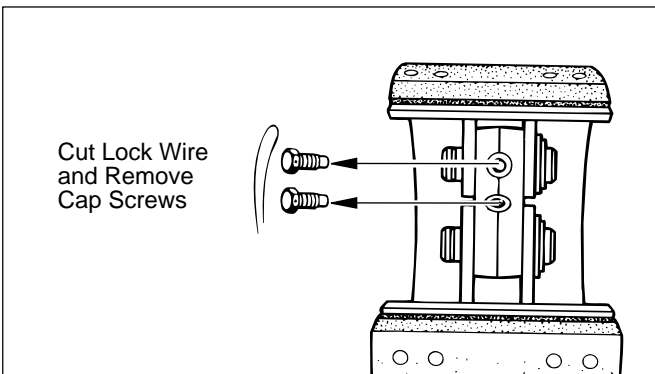

Figure 26. Cap Screw Removal

5. Remove upper anchor pin with a brass drift or a mallet. Refer to Figure 27.

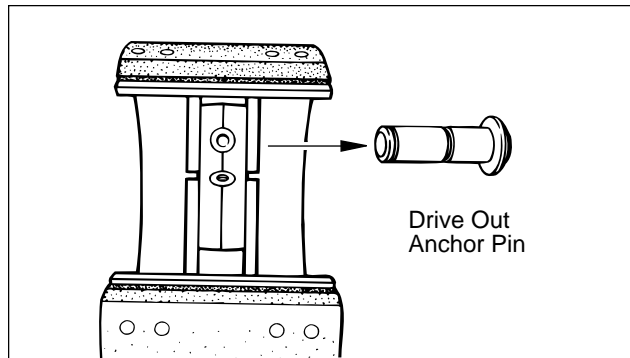

Figure 27. Anchor Pin Removal

6. Rotate upper shoe around cam end, disengage roller end from cam, then unhook return spring from shoe and remove upper shoe. Refer to Figure 28. Discard return spring.

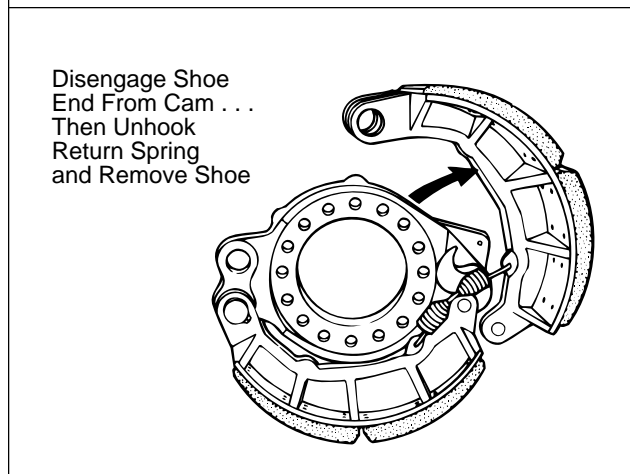
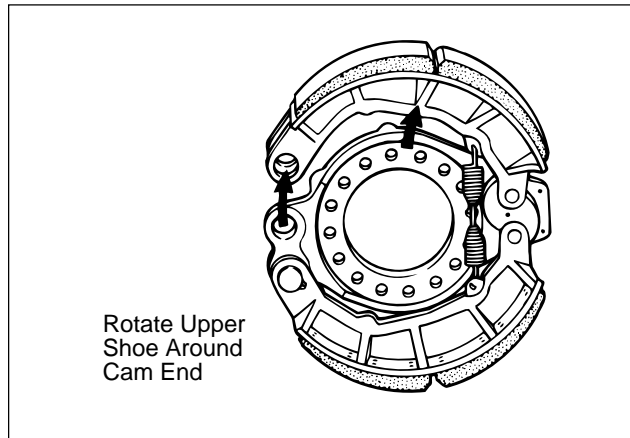

Figure 28. Shoe Removal

7. Remove lower anchor pin to remove lower shoe.

NOTE: Inspect anchor pin and bushings. If pin was seized or bushing is grooved or worn beyond 0.031" (0.79mm), replace pin and bushing. Always replace pins and bushings with brake relined.

8. Drive out the old anchor pin bushings from brake shoe and spider with a suitable driver. Refer to Figure 29.

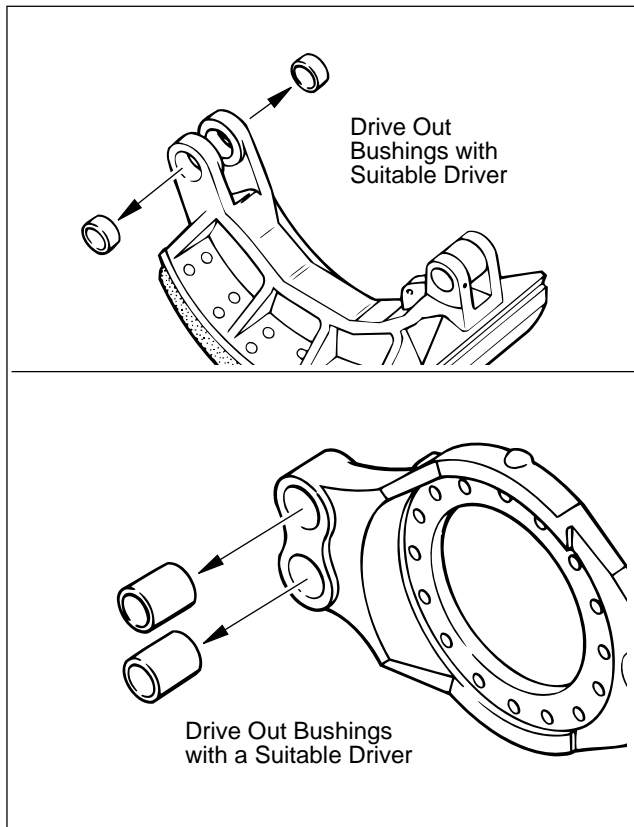

Figure 29. Anchor Pin Bushing Removal

9. Do not remove roller from the brake shoe, unless: the roller does not roll freely, there are flat spots on the roller, or there is more than 0.025" play between the roller and pin.

If removal of roller is necessary, use a steel punch to drive out the groove pin, then push the pin out of the shoe. Discard roller and pin. Refer to Figure 30.

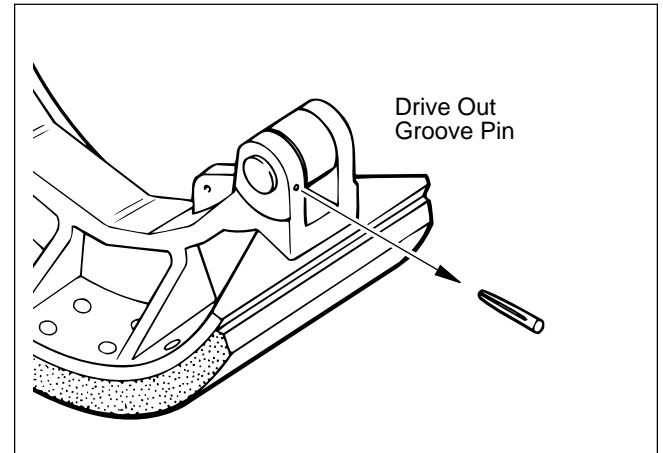

Figure 30. Groove Pin Removal

10. Clean and inspect remaining brake parts as outlined in **Removal/Disassembly** section of this manual.



Brake Adjuster Removal

1. Remove cotter pin and clevis pin from air chamber pushrod clevis.
 2. While depressing locking sleeve, turn adjuster nut until brake adjuster is clear of air chamber pushrod clevis. Refer to Figure 31.
- NOTE:** Follow manufacturer's instructions for self adjusting brake adjusters.

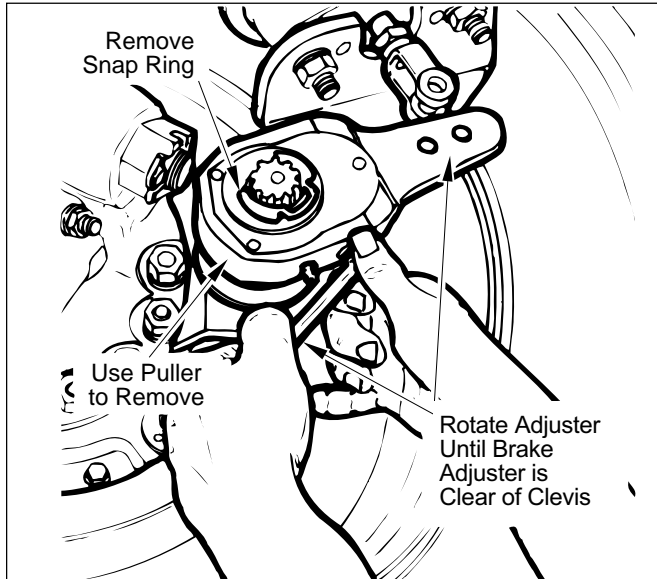

Figure 31. Brake Adjuster Removal

3. Remove snap ring and outer shim washer(s) from camshaft.



Bendix® ASA-5™ Automatic Slack Adjuster

4. Note orientation of brake adjuster with reference to push rod before removal to assure assembly is in proper orientation. Remove brake adjuster with a suitable puller.



CAUTION: Do not hammer on brake adjuster to remove! Damage to brake adjuster and/or camshaft splines may result.

Camshaft Removal

1. Perform all steps for drum, shoe, and brake adjuster removal as outlined in **Removal / Disassembly** section.
2. Grasp camshaft head and pull camshaft outboard to remove.

Air Chamber Bracket Removal

1. Perform all steps for drum, shoe, brake adjuster and camshaft removal as outlined in **Removal / Disassembly** section.
2. Disconnect chamber air line.
3. Remove the attaching nuts (bolts on brakes with cast spider) and pull the air chamber bracket away from the spider.

NOTE: On 16.5" diameter brakes with stamped spiders, the air chamber bracket-to-spider studs are press fit into the spider. Their removal is not required to remove the air chamber bracket.

NOTE: On ES & EB 150-4L brake a stabilizing nut has to be removed. The bracket-to-spider studs are pressed to fit into the air chamber bracket flange. Their removal is not required to remove the air chamber bracket.



WARNING: To prevent personal injury, be sure to "cage" spring before removing spring brake type air-chambers.

Spider Removal

1. Perform all steps for drum and shoe removal as outlined in **Removal / Disassembly** section.
2. Remove spider-to-axle attachment nuts and bolts. Refer to Figure 32.
3. Remove spider.

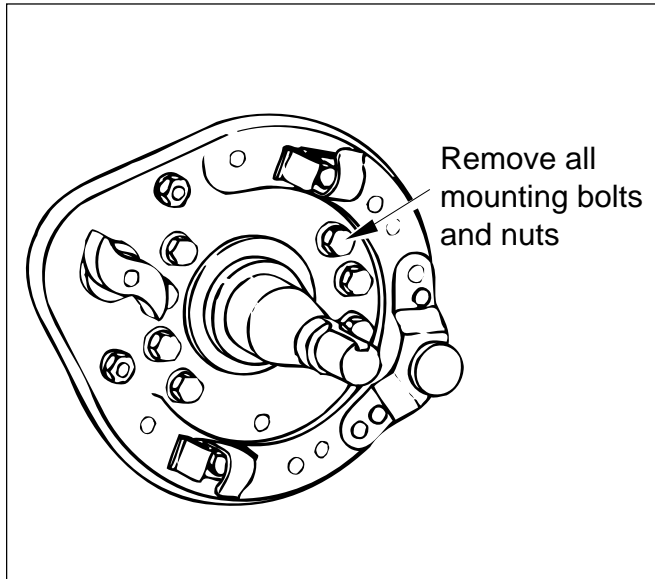

Figure 32. Spider Mounting Hardware Removal

Dustshield Removal

NOTE: On ES-165-7H, M Brakes, the dustshield is removed before shoes and anchor pins are removed.

1. If applicable, remove screws and retaining clip. Remove all screws attaching dustshield to spider (4-6 screws depending on model). Refer to Figure 33.
2. Remove dustshield.

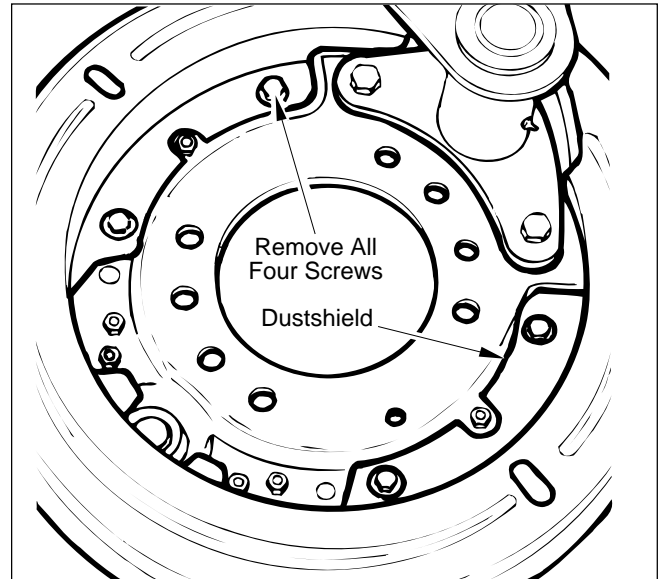
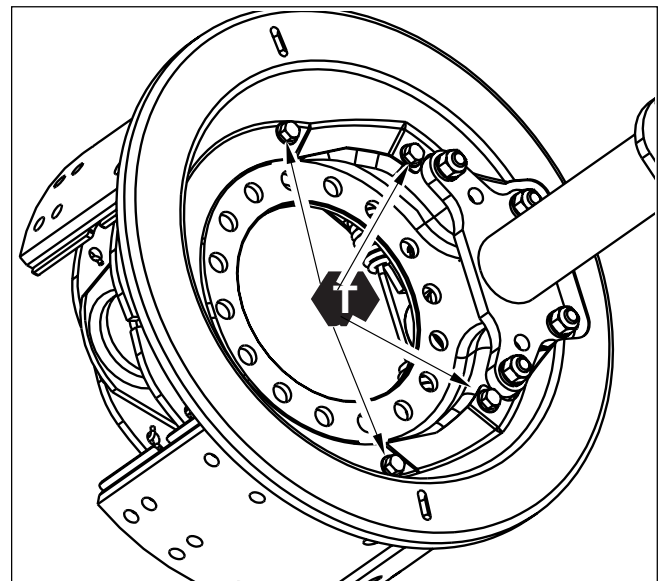

Figure 33. Dustshield Mounting Hardware Removal



For All 165-5,6,7,8L Models



Cleaning Brake Parts

After removing the brake parts to be serviced, the following cleaning procedures should be followed:

- Wire brush all parts exposed to mud, road dirt, and salt, including spider, air chamber bracket, dustshields and exterior of drum.



CAUTION: A layer of oxidation and dirt on the outside of a brake drum acts as an insulator and may hinder normal heat dissipation. Remove excessive deposits by wire brushing.

- Use a vacuum cleaner to remove brake dust from drums. Wipe interior of drums with a greaseless solvent to remove any spilled oil.



WARNING: The long term effects of non-asbestos fibers, have not been determined. Therefore, precautions should be used when handling these materials. Do not use compressed air to blow from interior of drums. Brake lining dust, when inhaled, can be injurious to health.

See General Information / Lining Material Warning

Drum Inspection

- Clean all remaining brake parts thoroughly with a suitable shop solvent. Wipe dry with a clean, lint-free cloth.

NOTE: This information is general in nature. For specific brake drum inspection guidelines, refer to the drum manufacturer's instructions.

1. Check for cracks, heat-checks, glazing, grooving, run-out and out-of-round. Refer to Figure 34. Cracked drums must be replaced. Drums which are glazed, grooved, out-of-round, etc., may be returned to service if they can be repaired without exceeding manufacturer's maximum diameter or run-out specifications.

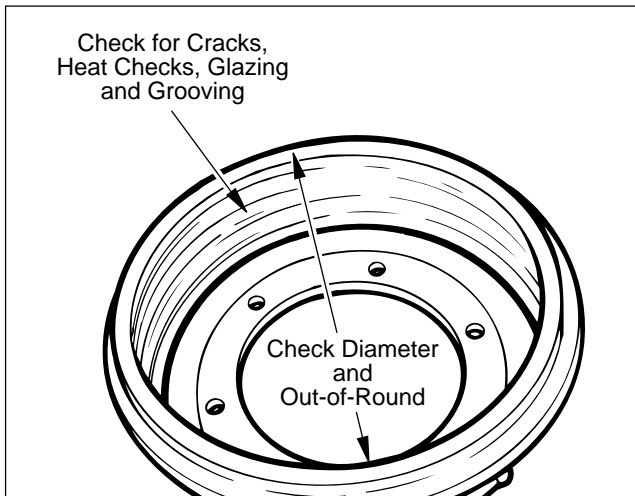

Figure 34. Drum Inspection

2. Check drum diameter. Replace drum if it exceeds maximum diameter stamped in drum.



CAUTION: Under no circumstances should drum be used if it exceeds manufacturer's recommended maximum diameter or run-out specification.

Drum Inspection

Bendix does not recommend the turning or reboring of brake drums. The reduction of wall thickness reduces the amount of thermal energy that can be absorbed by the drum during braking. Also, the decrease in wall thickness increases the amount of deflection for the same input load. Both of these are undesirable. If drums are refaced or oversized, the new diameter **MUST NOT** exceed the maximum diameter marked on the drum during its service life.



Inspection

Shoe and Lining Inspection

1. Check shoes for bent or cracked webs, or table, broken welds, loose rivets or elongated rivet holes. Refer to Figure 36. If any are found, replace with Bendix OEM grade lining and shoe assemblies.

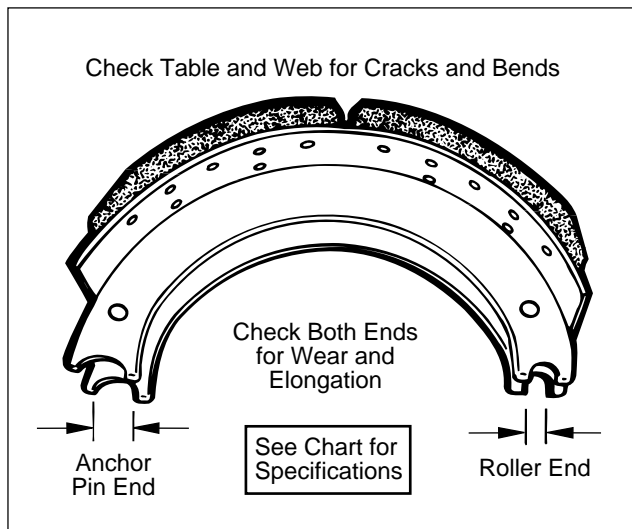

Figure 36. Shoe and Lining Inspection

2. Check anchor pin and cam roller contact areas in shoe webs for elongation or wear. Replace shoe if diameter exceeds the following specifications.

Brake Model	Roller End	Anchor Pin End
All EB, All ES-165 ES-150-4D, ES-150-8D, F & 6D	0.836"	1.400"
ES-165-7M	0.774"	1.280"

3. **ES-165-7H severe duty brake only:** Anchor pin bushings are mounted in these brake shoes. Refer to **Inspection-Spider Inspection** (Double Anchor Pin) for instructions.

NOTE: Two-piece roller and pin are mounted in brake shoes for 7H model brake. Do not remove roller and roller pin unless: the roller does not roll freely, there are flat spots on the rollers or there is more than 0.025" play between roller and pin. Replace roller and pin if these conditions are found.

4. Check the linings and replace with Bendix OEM grade shoe and lining assembly if contaminated, cracked, or worn to less than 1/4" (6.4mm) thickness at any point (see instructions below) or 3/16" (4.5mm) for EB/ES 150-4L brake.

NOTE: To eliminate premature Lining Replacement Bendix recommends the use of the Bendix Brake Lining Wear Gauge to accurately measure lining thickness. This tool is available through Bendix as BW7261.

Important: For use with air actuated cam brakes where minimum allowable lining thickness is 1/4 in. (Note: Do not use for strip linings on 15 x 4 brakes or similar brakes.)

1. With the brake not applied, place the tip of the gauge between the two lining blocks,

between the top of the shoe table and drum. Use the gauge to scrape away any mud, rust, or other contaminants that could interfere with proper lining measurement.

2. Remove the gauge from the brake.

3. With the vehicle's brakes applied, try to put the gauge between the two lining blocks and the top of the shoe table. Note "hook" of gauge allows insertion around worn drum lip. If the tip of the gauge will not fit between the brake drum and the top of the shoe table, the lining is worn below 5/16 inch and will need to be replaced.

4. If the tip of the gauge fits between the brake drum and the shoe table, the lining is not worn below 1/4 inch at this time.

5. Because brake shoes can wear at different rates, check both shoes on each brake and all brakes on the vehicle.

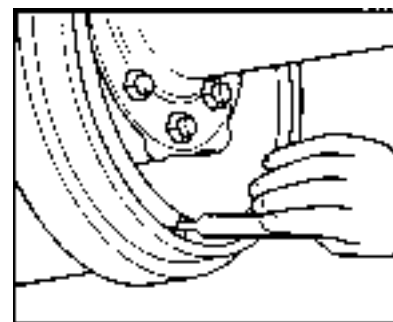
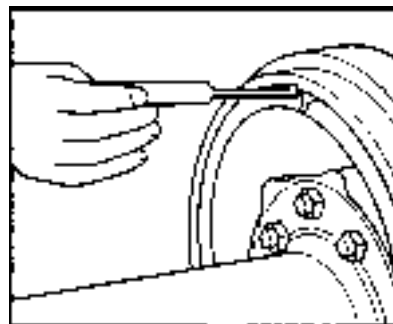

Shoe and Lining Inspection (cont'd)

Standard Production EB™ brakes use different shoe and lining assemblies than those used for the ES models. Because of these part differences, normal wear of either creates a unique lining wear pattern.

WARNING: The long term effects of non-asbestos fibers, have not been determined. Therefore, precautions should be used when handling these materials.

See General Information / Lining Material Warning

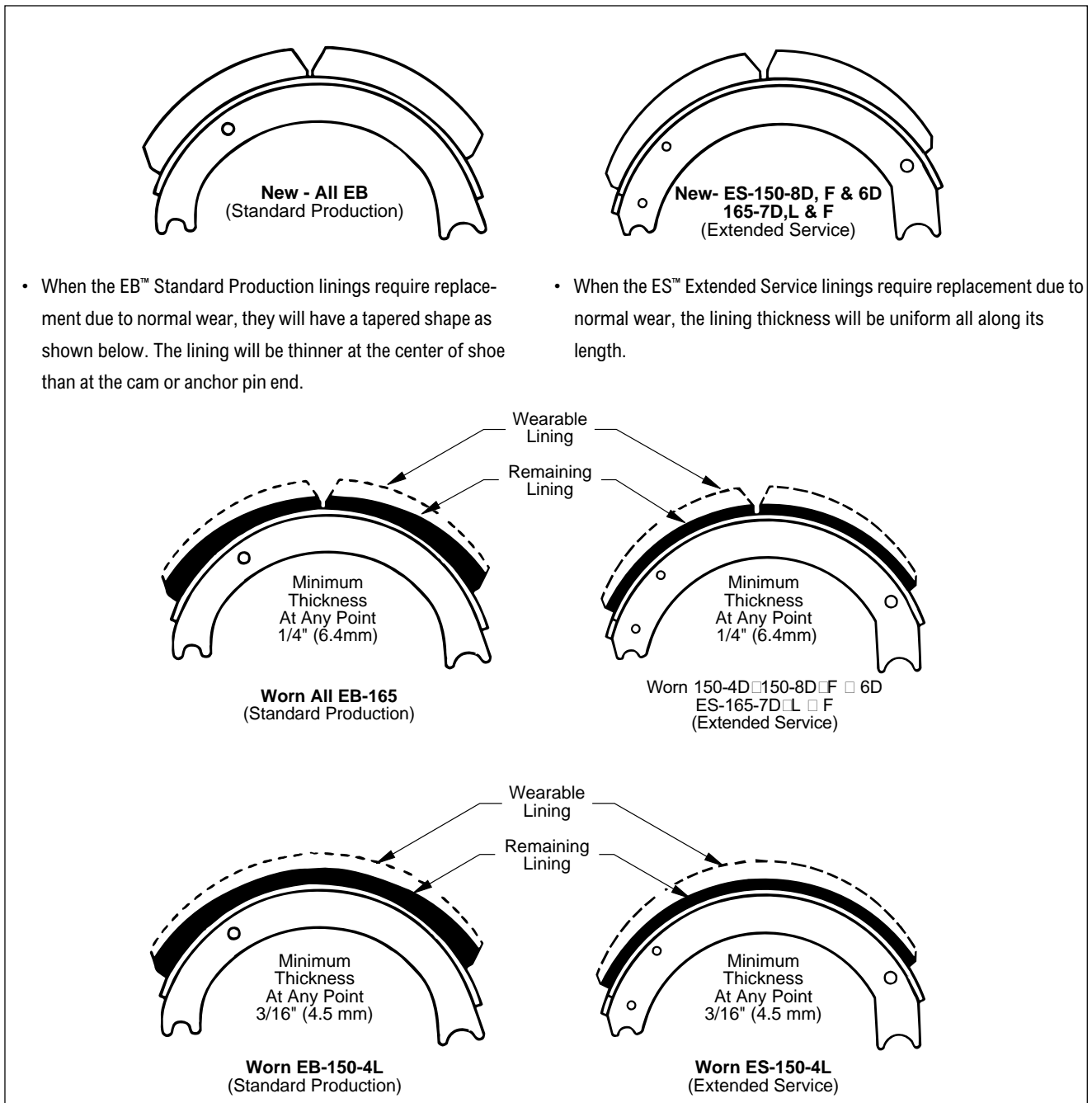

Figure 37. Brake and Lining Blocks



Inspection

Camshaft Radial Play Inspection

Camshaft radial play should be checked any time the brake shoes have been removed from the vehicle. Refer to Figure 38.

1. Mount a suitable dial indicator with plunger referencing cam head at roller contact area.
2. Zero dial indicator.
3. Move cam head up and down and note maximum reading.

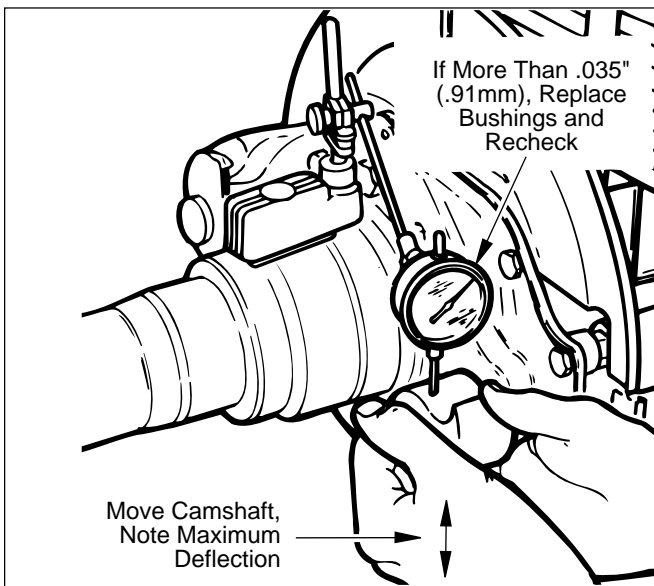

Figure 38. Camshaft Radial Play Inspection

4. If play exceeds 0.035" (0.91 mm), rebush air chamber bracket. See **Repair/Replacement - Camshaft Bushing and Grease Seal Replacement.**

NOTE: For Trailer Axle Brakes, rebush spider and/or replace support bushing assembly at brake adjuster. See **Repair/Replacement - Camshaft Bushing and Grease Seal Replacement.**

5. After rebushing, recheck radial play. If still excessive, replace camshaft.

Camshaft Inspection

1. Refer to Figure 39. Check spline end for cracks, worn or deformed splines. Replace as necessary.
2. Check camshaft bushing journals for wear and corrosion. Replace camshaft if it shows visible wear or if roughness is felt in journal areas.
3. Inspect camshaft head for brinelling, cracking or flat spots. Replace camshaft if a ridge can be felt between worn areas and cam head surface.

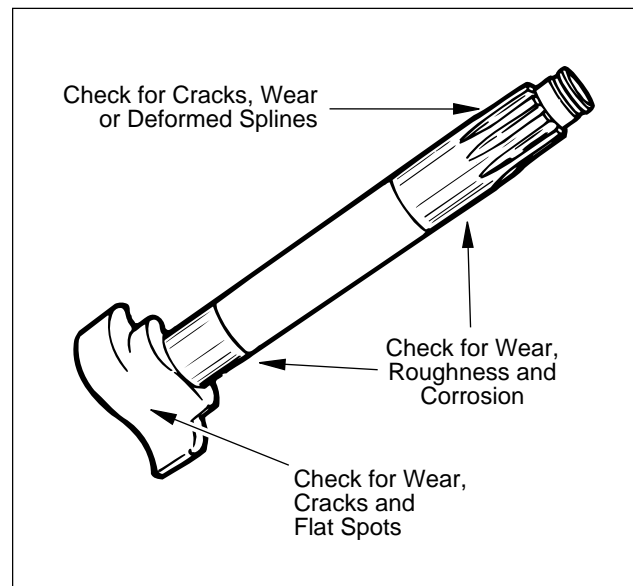

Figure 39. Camshaft Inspection

Camshaft Bushing and Seal Inspection

NOTE: Steer and drive axle camshaft bushings and seals are mounted in the air chamber bracket assembly.

1. Check bushing for deterioration or wear. Inner surface must be smooth. If surface is rough or abrasive, replace bushing, see **Repair/Replacement - Camshaft Bushing and Grease Seal Replacement.**
2. Inspect grease seals. Replace if seal lip is nicked, cut or distorted. See **Repair/Replacement - Camshaft Bushing and Grease Seal Replacement.**

Spider Inspection

Single Anchor Pin

1. Check visually for cracks around mounting bolt holes, in cam area and around anchor pin. Refer to Figure 40. Replace spider if any are found.
2. Check anchor pin. If loose or grooved more than 0.031" (0.79mm) below original surface, replace spider assembly.

NOTE: Anchor pins are not replaceable on single anchor pin brake spiders.

3. On EB/ES 150-4L brake check anchor pin retaining nut torque refer to the last page of this manual for current torque values.

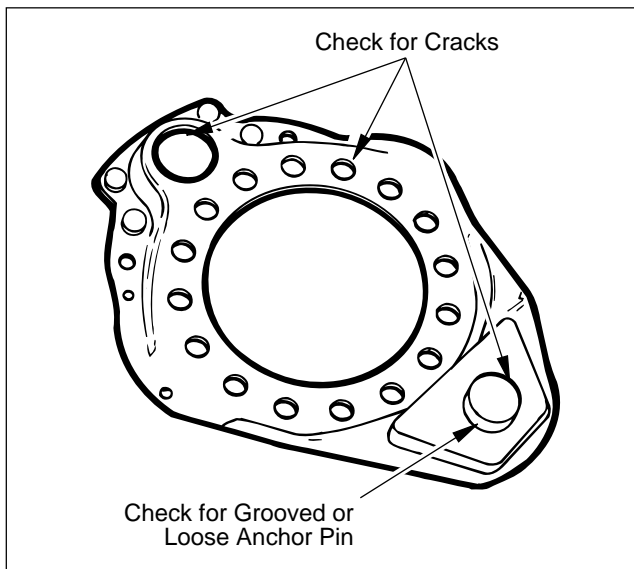

Figure 40. Spider Inspection

SPECIAL NOTE: ES and ES-150-4L R.H. brakes use a R.H. thread anchor pin retaining nut - L.H. brakes use a L.H. thread nut. Ensure that nut is being turned in proper direction when checking nut torque.

CAUTION: If anchor pin turns while checking retaining nut torque, the spider assembly must be replaced.

Spider Inspection (Double Anchor Pin)

1. Check visually for cracks around mounting bolt holes and cam and anchor pin areas. Replace spider if any are found.
2. Check anchor pin and bushings for wear, grooves and free movement of pin. If pin is seized, or worn or grooved beyond 0.031" (0.79mm), replace pin and bushing. Refer to Shoe Removal and Installation Sections for procedure.

NOTE: Replace pins and bushings at each brake reline.

Air Chamber Bracket Inspection

1. Check for a bent, broken, or cracked arm and cracked welds. Refer to Figure 41. Replace bracket if any are evident.
2. Check mounting studs (or bolts) for looseness, damaged threads, or a bent condition. Replace mounting stud if any of these conditions are evident.

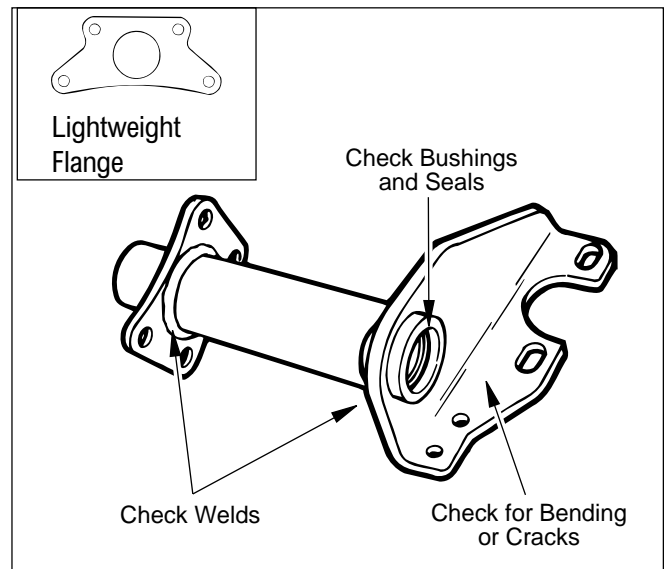

Figure 41. Air Chamber Bracket Inspection



Inspection

Air Chamber Inspection

WARNING: To prevent personal injury, be sure to “cage” spring before removing spring-brake type air chamber.

NOTE: This information is general in nature. For specific air chamber inspection guidelines, refer to the manufacturer’s instructions.

1. Check for air leaks, cracked housing, bent pushrod, loose clamp ring, clogged vent holes or loose air fitting. Repair or replace as recommended by the manufacturer.
2. If air chamber is repaired or replaced, check distance from clevis pin hole centerline-to-air chamber face. Refer to Figure 42 and Table 6 for manual brake adjusters. For self adjusting brake adjusters refer to manufacturers guidelines.

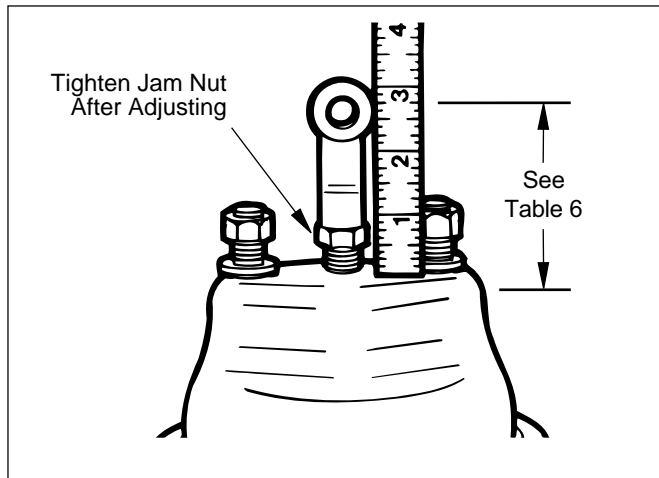

Figure 42. Air Chamber Inspection

Distance: Clevis Pin Hole Centerline to Air Chamber Face	
All brakes (except Mack and Trailer Axle)	2-5/8" ± 1/16" (66.7 ± 1.59 mm)
Mack brakes	4-3/8" ± 1/16" (111.1 ± 1.59 mm)
Trailer Axle brakes	6-1/2" ± 1/8" (165.1 ± 3.175 mm)

Table 6. Distance: Clevis Pin Hole Centerline to Air Chamber Face

3. If a new air chamber is installed, ensure that cut-off pushrod does not project too far into clevis. Minimum clearance: clevis centerline to pushrod end should be 7/8" (22.2 mm).
4. Check clevis pin for cracks and wear.

Brake Adjuster Inspection

NOTE: This information is general in nature. For specific manual or self adjusting brake adjuster inspection guidelines, refer to the manufacturer’s instructions.

1. Check clevis pin bushing for cracks and wear. Refer to Figure 43. Replace as necessary.

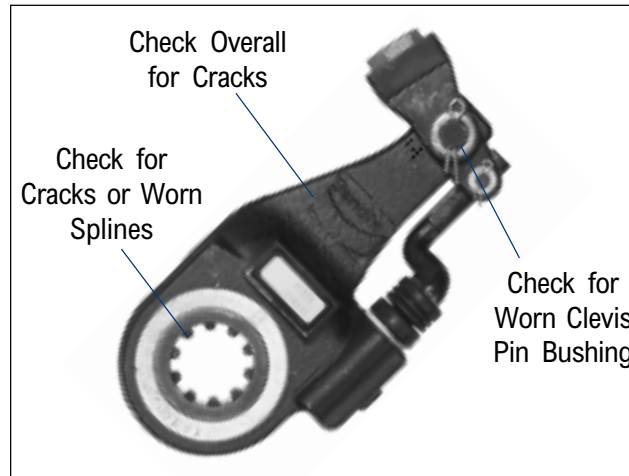

Figure 43. Automatic Slack Adjuster Inspection

2. Check splines for chipped teeth and deformation. Replace brake adjuster if necessary.
3. Depress locking sleeve and turn brake adjuster adjustment nut with a wrench at least one turn in each direction. If binding is present or if excessive force is required to rotate, replace the brake adjuster.



CAUTION: If any of those conditions are found, the brake adjuster should be replaced. Do not attempt to repair a faulty brake adjuster!

Camshaft Bushing/Lining Replacement

Routinely replace lower-cost items such as springs, seals, bushings, and heavily-worn but unbroken parts since the damage caused, should these components fail, is far in excess of their cost.

Camshaft Bushing/Grease Seal Replacement

1. Remove air chamber bracket, see **Removal / Disassembly - Air Chamber Bracket Removal**.
2. Drive out old bushings and grease seals with a suitable driver.
3. Clean and inspect air chamber bracket, see **Inspection - Air Chamber Bracket Inspection**.
4. Install new bushings in air chamber bracket (Drive and Steer Axles) with a suitable piloted driver. For identification and installation specifications, refer to Figure 44 and Table 7.

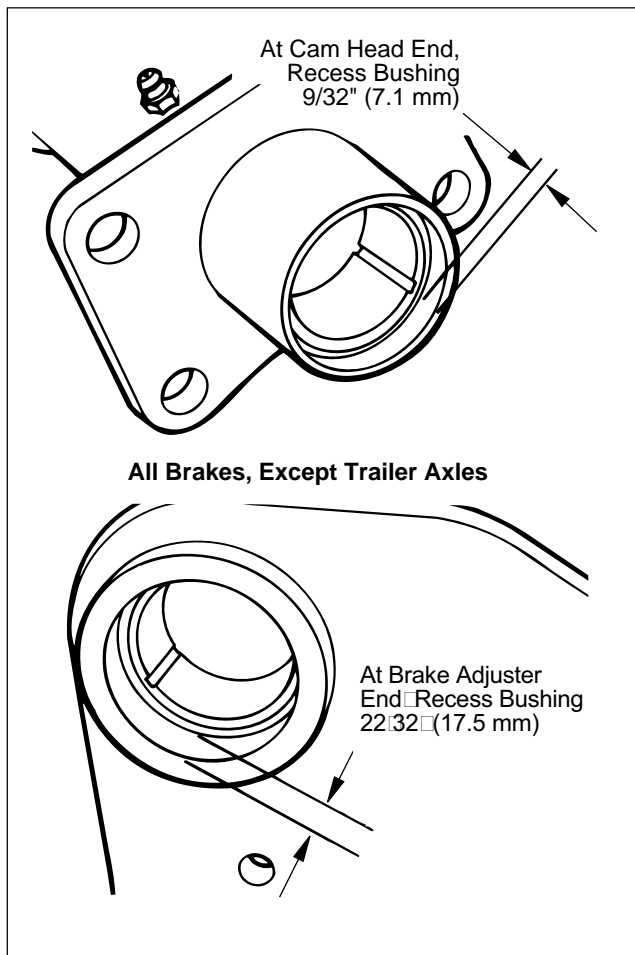

Figure 44. Air Chamber Bracket Bushing Installation

Brake Model	At Cam Head	At Brake Adjuster
EB-150L		
EB-165D, L, F and ES-165D, L, F ES-150L, D, F	Non-metallic	Non-metallic
ES-165M, H and EB-180	Bronze	Non-metallic
Installation Specs: (All except Trailer Axle)	Recessed 9/32" (7.1mm) from tube end.	Recessed 22/32" (17.5mm) from tube end.
Trailer Axle Spider Bushings	Flush with inner recess shoulder at each end of spider (to allow space for the seals).	
NOTE: Non-metallic bushings are labeled. Install these bushings with labeled ends facing each other.		

Table 7. Camshaft Bushing Installation Specifications

Note: The LMS Low Maintenance Systems uses a bronze bushing at the cam head (with the exception of the LMS 15 x 4 brakes.)

5. Install new grease seals with a suitable piloted driver so seals are flush with end of air chamber bracket tube. Refer to Figure 45.

CAUTION: Seals must be installed as indicated so that lip side (with spring) of both seals faces toward brake adjuster end of bracket. Improperly oriented seals may allow grease to exit camshaft head end of air chamber bracket and contaminate lining material.

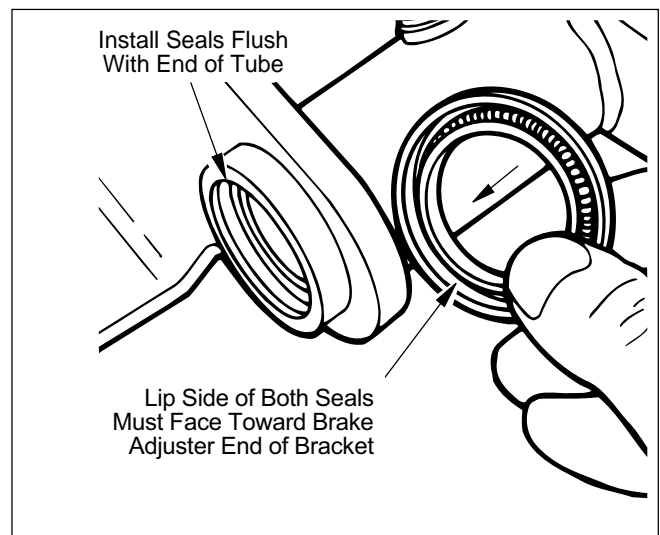

Figure 45. Camshaft Bushing Installation

Spider / Air Chamber & Brake Adjuster Inspection



Lining Replacement



WARNING: The long-term effects of non-asbestos fibers have not been determined. Therefore, precautions should be used when handling these materials.

See **General Information / Lining Material Warning**

NOTE: Reline brakes when inspection indicates replacement is necessary, see **Inspection - Shoe, and Lining Inspection**. When replacing lining only, make sure shoes are in good condition. For replacement, use only Bendix OEM grade linings or shoe and lining assemblies.

1. Remove shoe and lining assemblies.
2. Remove lining blocks.
 - If blocks are riveted, use a suitable riveting mandrel to push out rivets.



CAUTION: Drilling out rivets or cutting off upset head with a chisel may cause rivet or bolt hole elongation.

- If blocks are bolted, remove using suitable tools. Discard bolts.
- Inspect shoe to be sure it can be reused.

3. Clean shoe with solvent if necessary and wire brush shoe table. Paint with rust inhibitive paint.

4. Install lining blocks.

NOTE: When installing linings or blocks, make sure they are positioned properly to match rivet or bolt patterns. Refer to Figure 46.

For Riveted Linings: Assemble linings to shoes with rivets shown below, installing them in sequence shown in Figure 46.

ES-150-6 & 8, ES-165: Bendix Part No. 813250.

EB/ES-150-4L, EB-165: Bendix Part No. 813250.

For Bolted Linings: Using machine screws provided in lining kit (807933), assemble blocks to shoes in sequence shown in the illustration for EB-180 brakes. Torque nuts as specified on installation note provided within the lining kit. **T**

5. Check lining installation by trying to insert a .006" (.15 mm) feeler gauge between lining and shoe table along edges. It should not be possible to insert feeler gauge in this manner anywhere along edge with exception of outside ends beyond last row of rivets. A larger clearance may exist in these areas.

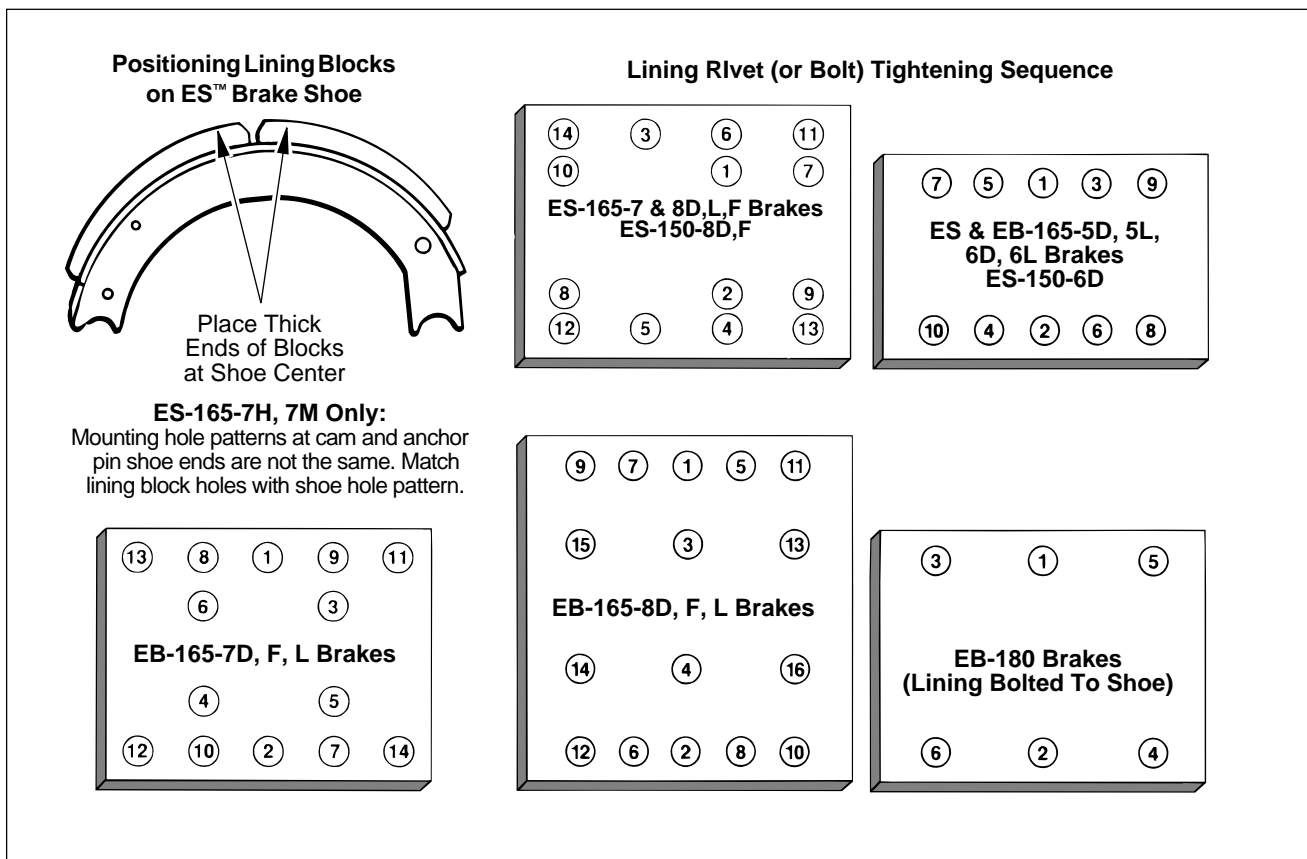

Figure 46. Lining Rivet (or Bolt) Tightening Sequence

Spider Installation

SPECIAL NOTE: For ES/EB-150-4L distinct right-hand and left-hand spider assemblies are used on this brake. Although similar in appearance, differences exist in anchor pin and retaining nut threads - L.H. brake uses L.H. threads and R.H. brake uses R.H. threads.

1. Verify the available spider is serviceable, see **Inspection - Spider Inspection**.
2. Verify that available spider is correct part number for axle being serviced.
3. Position spider on axle flange and install attaching bolts and nuts.

NOTE: Use hardened washer under bolt heads.

4. Sequentially torque nuts according to manufacturer's specifications, Refer to Figure 47. **T**

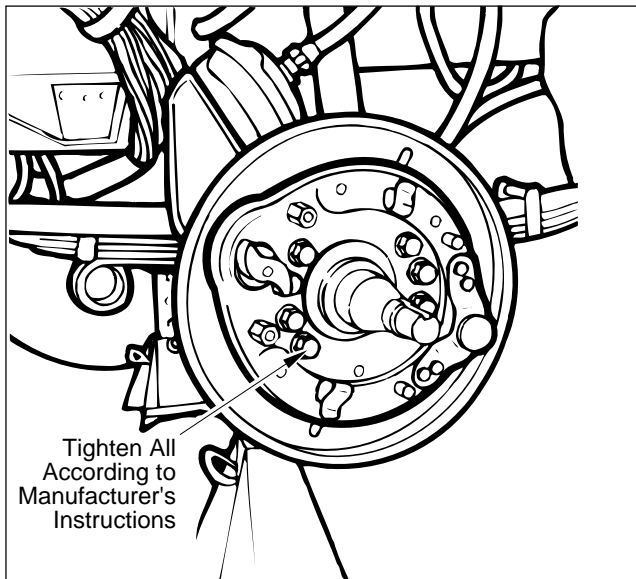

Figure 47. Installing Spider Mounting Hardware

Dustshield Installation (Two Piece)

NOTE: On ES-165-7H, M Brakes, the dustshield is installed after shoes and anchor pins are installed, see **Installation / Assembly - Shoe Installation**.

1. Place both dustshield into position against spider. Install all attaching screws finger tight.
2. Install retaining clip and screws, if applicable.

3. Reposition dustshield as required to allow a uniform space of 1/8" (3.2 mm) all along parallel mating edges. Refer to Figure 48.

4. Torque attaching screws to proper torque;

see **Specifications** chart. **T**

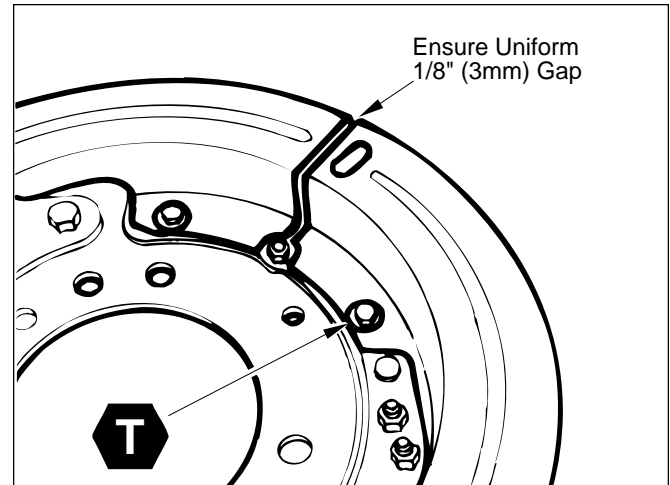

Figure 48. Dustshield Spacing

SPECIAL NOTE: For EB/ES-150-4L brake, a designed interference fit at upper dustshield to air chamber bracket area may cause the need to deform upper dustshield by hand slightly to allow upper dustshield half to align properly with the lower half. Refer to Figure 49.

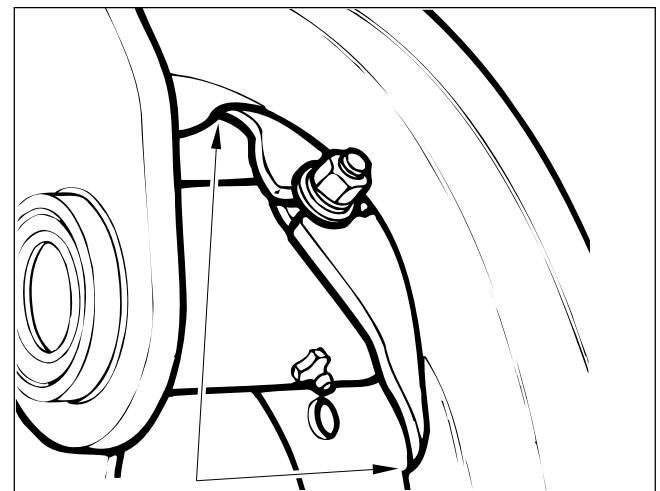



Figure 49. Designed Interference Fit



Dustshield Installation (One Piece)

1. Position dustshield against spider and install screws finger tight.
2. Torque attaching screws to proper torque; see **Specifications Chart** and Figure 50. 

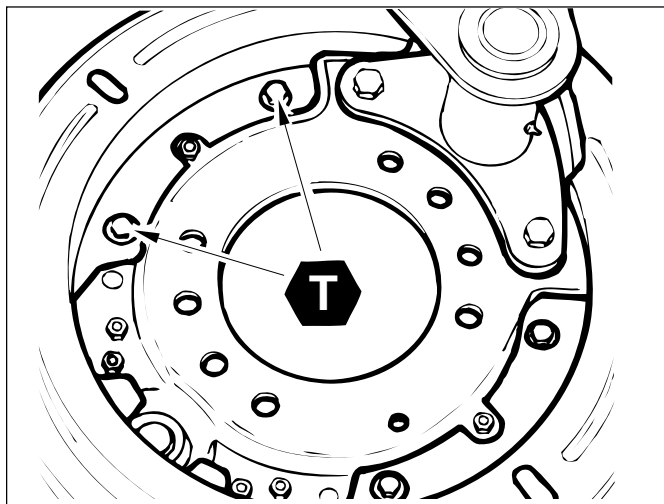
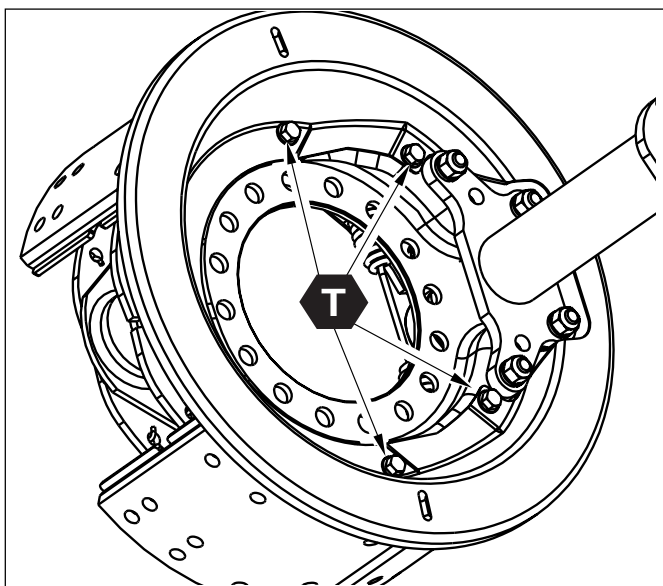

Figure 50. Attaching Screw Location



Air Chamber Bracket Installation

1. Verify that available air chamber bracket is serviceable, see **Inspection - Air Chamber Bracket Inspection**.
2. On stamped steel spider, orient bracket to align mounting studs with holes in bracket.
3. Position bracket against spider and install lockwashers and nuts.
4. Torque stud nuts to proper torque; see **Specifications** chart. **T**
5. On cast spider orient bracket to align bracket holes with tapped holes in spider.
6. Position bracket against spider and install bolts and lockwashers.
7. Torque bolts to proper torque; see **Specifications** chart. **T**
8. If air chamber was removed, install chamber and tighten nuts to correct torque; see **Specifications** chart. **T**

Air Chamber Bracket Installation

EB/ES-150-4L Brake

1. Verify that available air chamber bracket is serviceable. Refer to **Removal/Disassembly - Air Chamber Bracket Removal**.
2. Orient bracket to align stabilizing screw with slot in spider and mounting studs with holes in spider.
3. Position bracket against spider and install lockwashers and barrel (or standard) nuts on mounting bolts. Refer to Figure 51.

NOTE: Two brake shoe hold-down spring designs are used on the Model 150 Brakes, see **General Information - Parts Nomenclature**.

! **CAUTION:** Barrel nuts used in EB-150 brakes must be retained. Failure to reinstall may cause shoe twist, excessive noise or improper brake performance.

4. Torque barrel (or standard) nuts to proper torque, see **Specifications** chart. **T**
5. Install plain washer, lockwasher, and nut on stabilizing screw.
6. Torque nut to proper torque, see **Specifications** chart. **T**

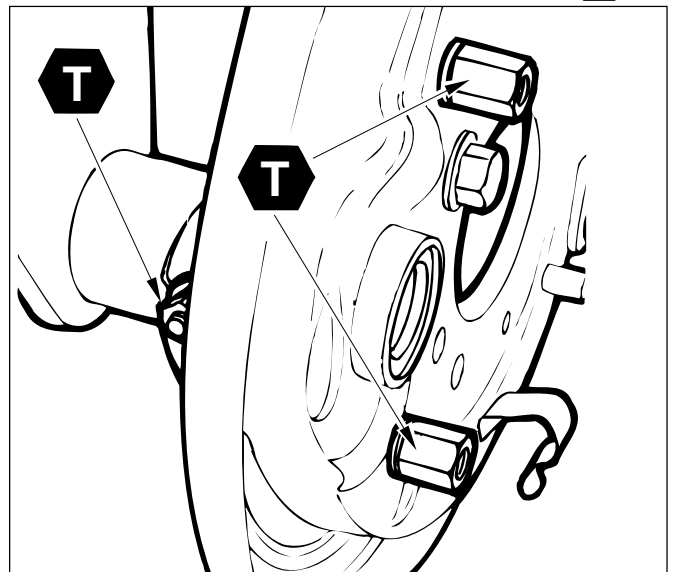

Figure 51. Air Chamber Bracket Mounting Hardware



Camshaft Installation

1. Verify that available camshaft is serviceable and is the correct part for the application, see **Inspection - Camshaft Inspection**

NOTE: Camshaft mounting and related parts vary with Brake Models. Be sure to follow instructions for special parts when installing camshafts.

CAUTION: Ensure the camshaft being installed is correct for the application.

2. To ensure that camshaft being installed is correct for the application, rotate camshaft in the direction of air chamber push rod extension and check that the roller starts to ride up on the convex side of the cam head. Refer to Figure 52.

3. Apply a thin film of chassis grease on inside of camshaft bush and seals, and on spline area of camshaft.

CAUTION: Do not grease cam head surface. For efficient operation, this surface must remain free of oil, grease or other contaminants.

4. Carefully slip camshaft into mounting position.

SPECIAL NOTE: For ES-165-7M, H,F install flat washer adjacent to cam head before installing camshaft.

On ES-165-5/6/7,8D, L Brakes, camshafts use a special washer between the cam head and spider. It is important that this washer be installed correctly. Refer to Figure 53.

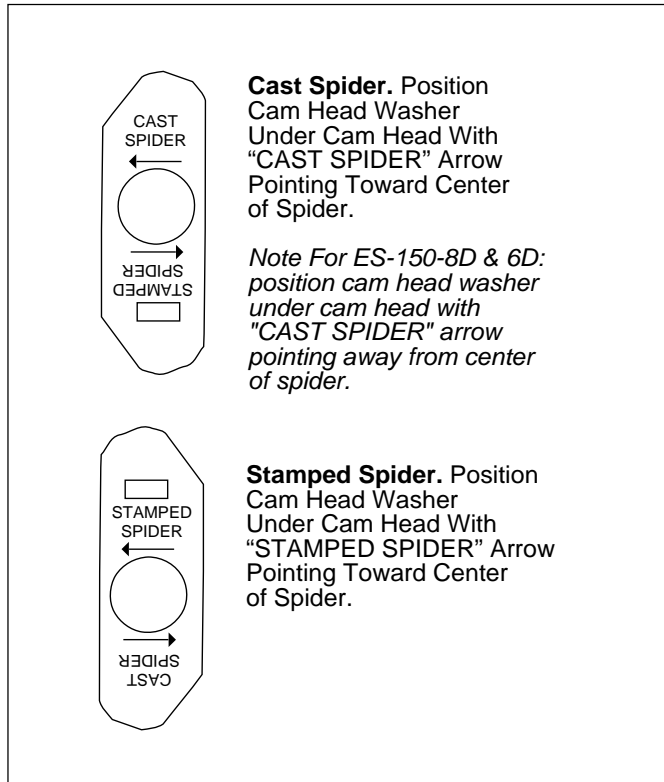

Figure 53. Cam Head Washer Installation

SPECIAL NOTE: For ES-165-5,6,7 DL steer axle brakes using the horse collar spring retention system, position the cam headwash with the "stamped spider" arrow pointing towards the center of the spider. The horse collar should be placed over the cam tube first then the ES washer and finally the cam.

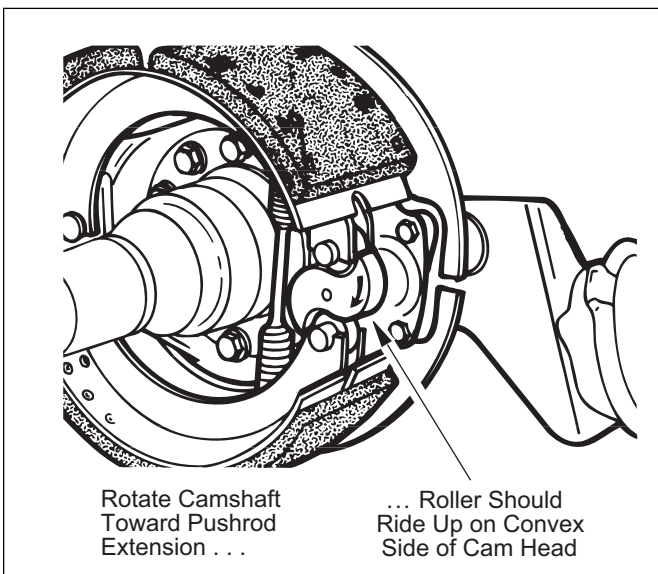
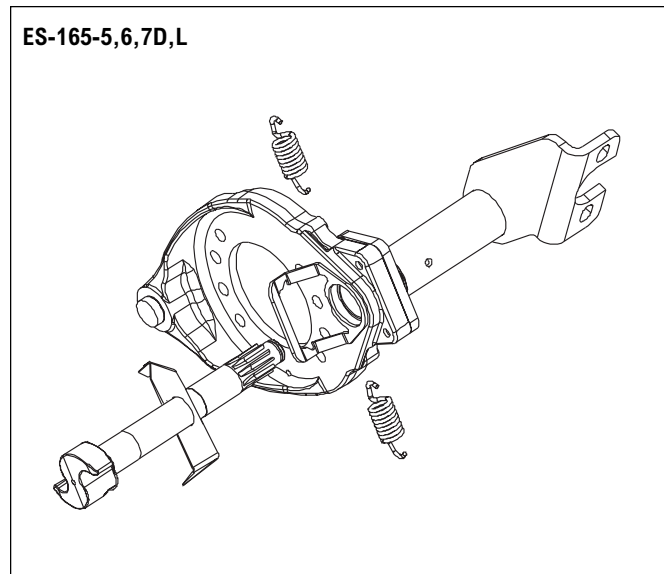

Figure 52. Camshaft Installation



SPECIAL NOTE: For ES-1 655,6,7D,L Steer axle brakes using the horse collar spring retention system, position the cam head washer with the “stamped spider” arrow pointing towards the center of the spider. The horse collar should be placed over the cam tube first, then the ES washer & finally the cam.

Cam Head Washer Installation Brake Adjuster Installation

1. Verify that brake adjuster is serviceable, see Inspection - Brake Adjuster Inspection.
2. Install brake adjuster inner washer on camshaft. Washer is identified by its 0.060" thickness and larger hole (see Figure 54).

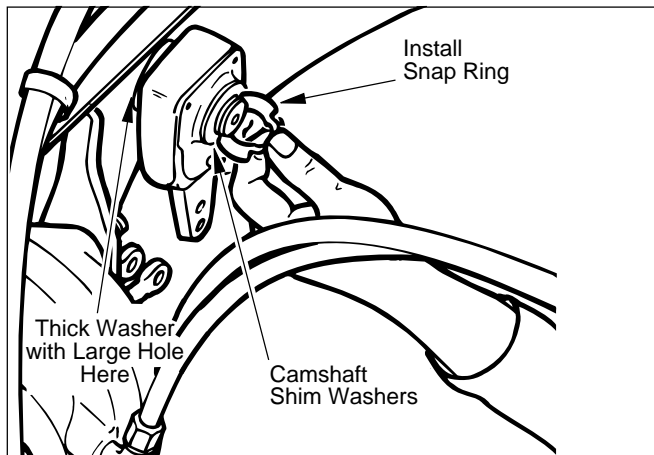

Figure 54. Shim Washer and Snap Ring Installation

3. Apply a thin film of chassis grease to brake adjuster splines.
4. Install brake adjuster on camshaft in the same position as noted before removal.

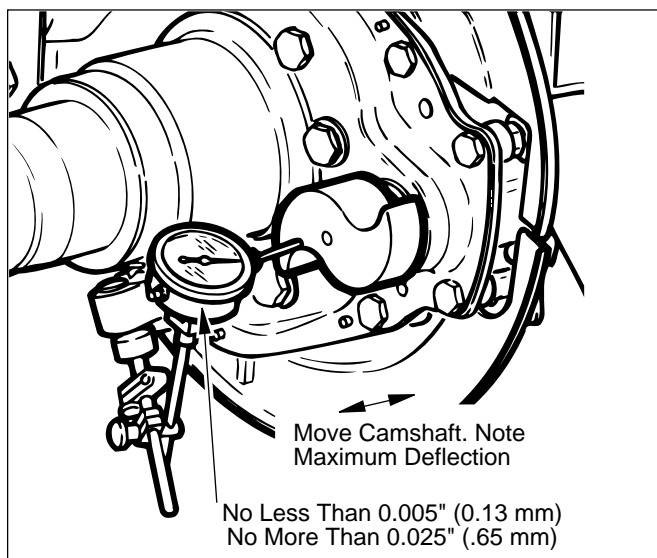

Figure 55. Brake Adjuster End Play Check

5. Install camshaft shim washers and snap ring. Refer to Figure 54. Check and adjust camshaft axial play (see step 6).

NOTE: Camshaft axial play must be checked before camshaft installation is complete. Follow instructions below.

6. Mount a suitable dial indicator with plunger referencing end of cam head. Refer to Figure 55.
7. Pull inboard on brake adjuster end of cam to take up end play.
8. Zero dial indicator.
9. Push outboard on brake adjuster end of cam and note maximum reading. If necessary, add or delete camshaft shim washers to obtain end play between 0.005" - 0.025" (0.13 - .65 mm) with brake adjuster centered between air chamber bracket and snap ring groove.
10. Pressure lubricate brake adjuster according to manufacturer's instructions. Pressure lubricate air chamber bracket until grease flows out of brake adjuster end of tube. Refer to Figure 56.

CAUTION: Grease should not flow out end of tube toward cam head. If it does, seal is defective and must be replaced.

CAUTION: Do not replace existing grease fitting with a pressure relief type. Only standard non-vented fittings are to be used with spring loaded lip seals.

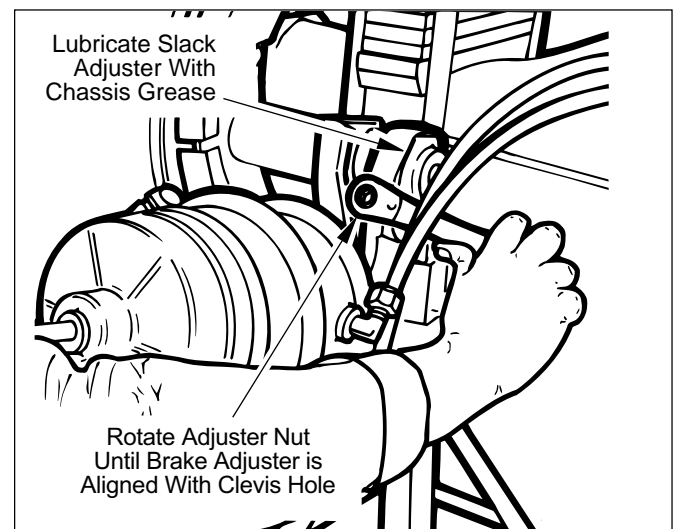

Figure 56. Brake Adjuster Lubrication and Adjustment



Shoe and Lining Installation

Brake Model	Page Number
EB-150-4L	44
EB-165-5D	46
EB-165-5L	46
EB-165-6D	46
EB-165-6L	46
EB-165-7D	46
EB-165-7L	46
EB-165-7F	46
EB-165-8D	46
EB-165-8F	46
EB-165-8L	46
EB-180-7R	46
ES-150-4L	44
ES-150-6D	45
ES-150-8D	45
ES-150-8F	45
ES-165-5D	46
ES-165-5L	46
ES-165-6D	46
ES-165-6L	46
ES-165-7D	46
ES-165-7F	46
ES-165-7H	50
ES-165-7L	46
ES-165-7M	48

Table 8. Shoe Installation Procedure Index

11. Verify that air chamber face-to-clevis centerline dimension is correct, see **Inspection - Air Chamber Inspection**. Ensure that clevis lock nut is securely tightened.

12. While depressing locking sleeve, rotate adjusting nut as required until appropriate hole in brake adjuster is aligned with hole in air. Refer to Figure 56.

13. Install clevis pin and cotter pin.

Shoe and Lining Installation

An index to the location of shoe installation procedures is provided in Table 8. Locate the brake model under service to identify the location of the appropriate shoe installation procedures.

EB/ES-150-4L Brake

1. Verify that spider, camshaft, air chamber bracket, and brake adjuster are serviceable and properly installed.

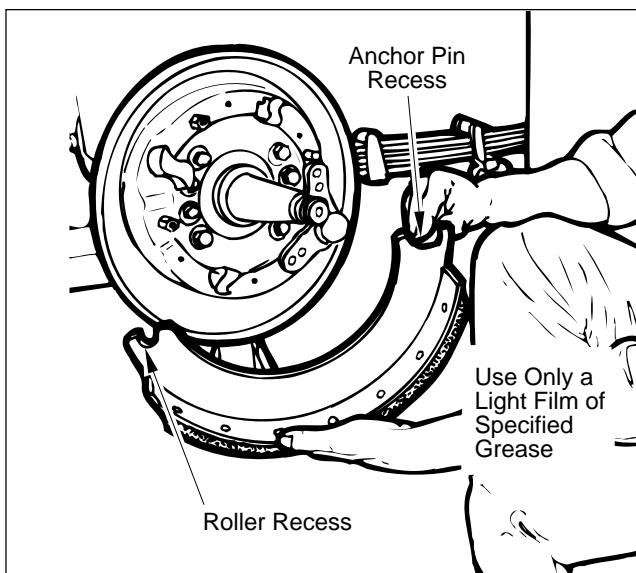

Figure 57. Shoe Web Lubrication

NOTE: See **General Information - Parts Nomenclature** for shoe hold-down spring variations.

2. Apply a thin film of grease to cam roller and anchor pin recesses of each shoe web. Refer to Figure 57.



CAUTION: Use only grease conforming to NLGI grade #1, high-temperature, waterproof.

3. Position upper shoe and lining web on anchor pin and rotate down. Continue rotation until shoe is held in place by shoe hold-down spring.

4. Hook one end of a new shoe retaining spring into hole in upper shoe web so coil lays across anchor pin. Refer to Figure 58.

5. Hook opposite end of spring into hole on lower shoe web.

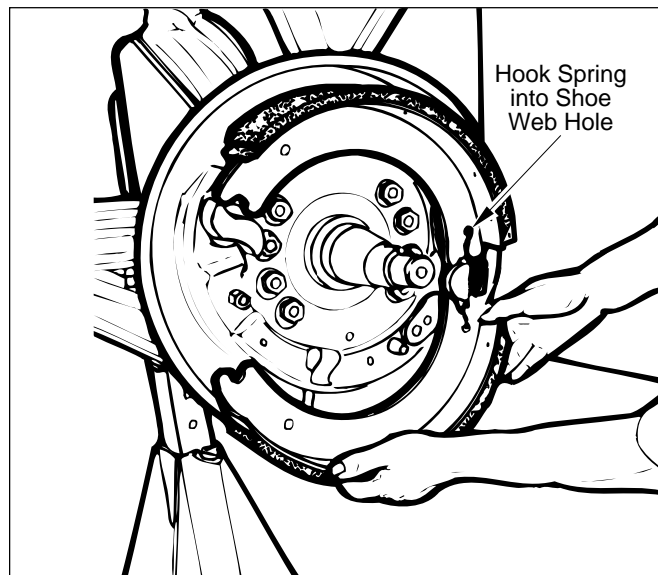

Figure 58. Shoe Retaining Spring Installation

6. Stretch spring to allow positioning of lower shoe web against anchor pin.

7. Rotate lower shoe into position on spider.

8. Hook end of a new shoe return spring in lower shoe web hole. Using a screwdriver for assistance, stretch shoe return spring to hook it in upper shoe web hole. Refer to Figure 59.

9. Using a large screwdriver or lever with tip, stretch shoe return spring to allow insertion of a new cam roller on upper shoe web.

10. Install a new cam roller on lower shoe web in same manner.

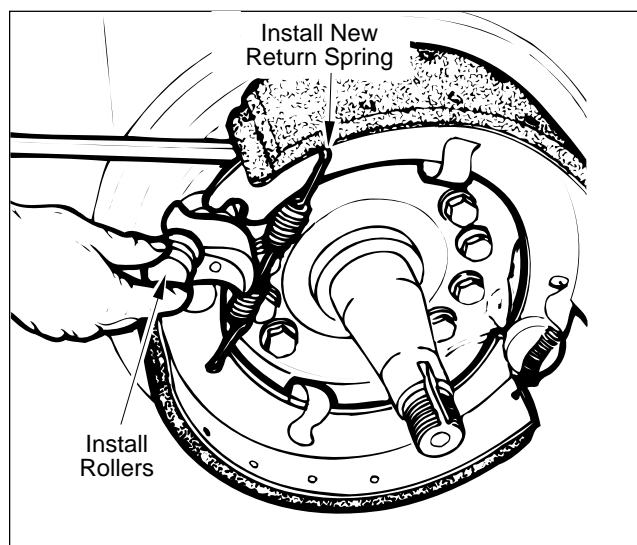

Figure 59. Shoe Return Spring and Roller Installation



Shoe And Lining Installation

NOTE: The following procedures are divided into sections, identified by brake model numbers.

ES-150-8D, F&6D

1. See **Inspection & Repair / Replacement** to verify that spider camshaft, bracket, and brake adjuster are serviceable and properly installed.

2. During shoe installation, lubricate:

- Shoe roller recess - one-piece roller.

CAUTION: Use only grease conforming to NLGI grade #1, high-temperature, waterproof.

Do Not Lubricate:

- Cam head surface. For efficient operation, this surface must remain free of oil, grease or other contaminants.

3. Position upper shoe on anchor pin and cam.

4. Install retaining springs by butting bottom shoe against anchor pin and top shoe. Install spring hooks in holes on webs. (Be sure hooks are fully engaged before rotating lower shoe around anchor pin.)

5. Position upper and lower shoes around anchor pin. Refer to Figure 60.

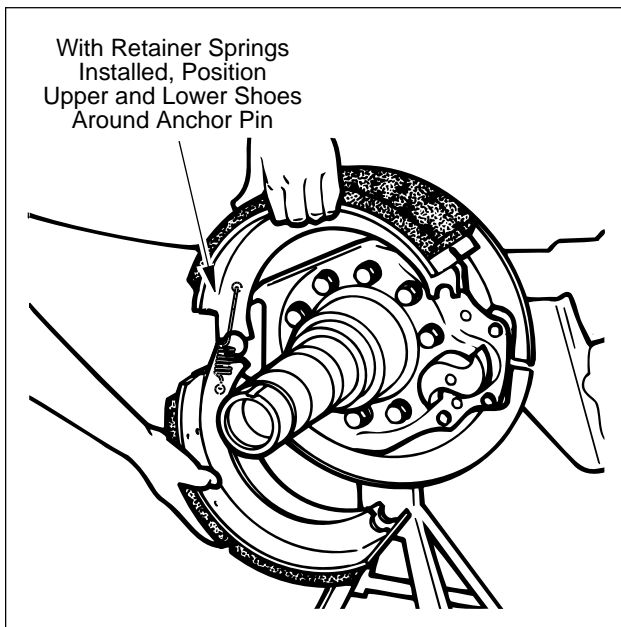

Figure 60. Upper and Lower Shoe Positioning

CAUTION: When the retaining spring passes the anchor pin, the shoes may close very rapidly.

WARNING: The long term effects of non-asbestos fibers, have not been determined. Therefore, precautions should be used when handling these materials.

See General Information / Lining Material Warning

6. The shoes may close rapidly when the return spring hook passes the center of the anchor pin (watch fingers.) Install a new shoe return spring. On ES-150-6D steer brake install new return springs between spring post and shoe with spring hooks towards the cam. Refer to Figure 61.

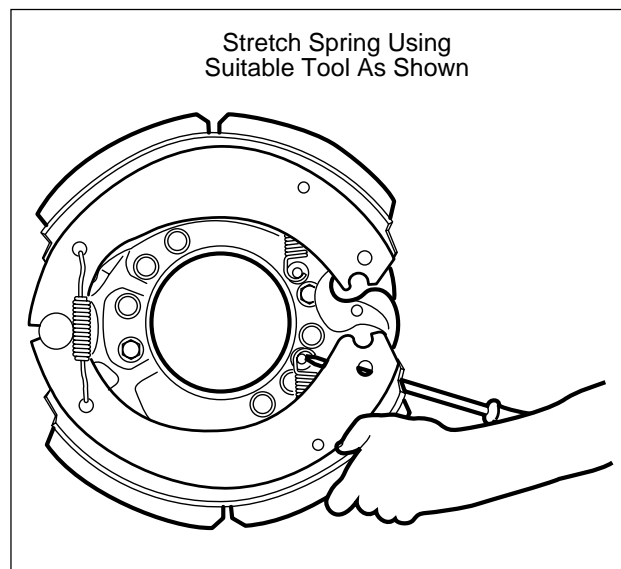

Figure 61. Shoe Return Spring Installation

NOTE: A lever or spring tool may be required to assist in hooking shoe return spring.

All EB (except EB-150-4L) and ES-165 5/6/7/8D,F,L

NOTE: The following procedures are divided into sections, identified by brake model numbers.

1. See **Inspection & Repair / Replacement** to verify that spider camshaft, bracket, and brake adjuster are serviceable and properly installed.

2. During shoe installation, lubricate:

- Shoe roller recess - one-piece roller.
- Roller I.D. - two-piece roller.

CAUTION: Use only grease conforming to NLGI grade #1, high-temperature, waterproof.

Do Not Lubricate:

- Cam head surface. For efficient operation, this surface must remain free of oil, grease or other contaminants.

3. Hook ends of new retainer springs into holes in both shoe tables, hooks pointing out.

4. Position upper and lower shoes around anchor pin. Refer to Figure 62.

WARNING: The long term effects of non-asbestos fibers, have not been determined. Therefore, precautions should be used when handling these materials.

See General Information / Lining Material Warning

5. Install a new shoe return spring. Refer to Figure 63.

NOTE: On ES-165-D, 1, F, a lever may be required to assist in hooking shoe return spring.

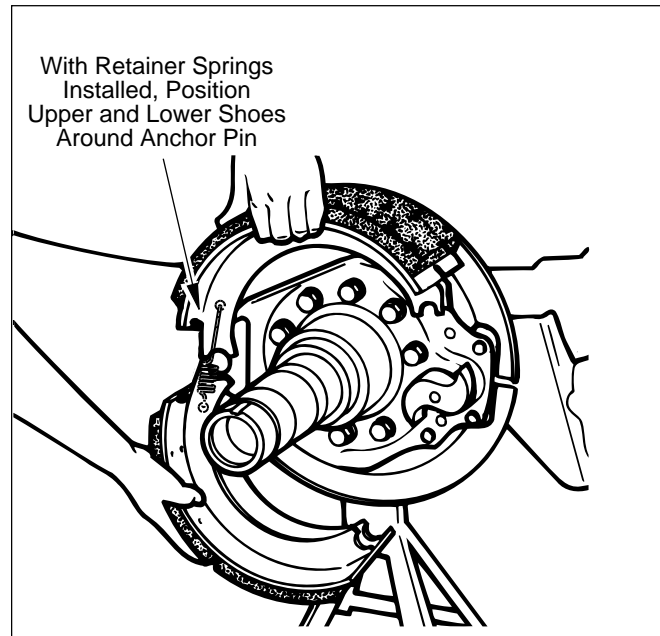

Figure 62. Upper and Lower Shoe Positioning

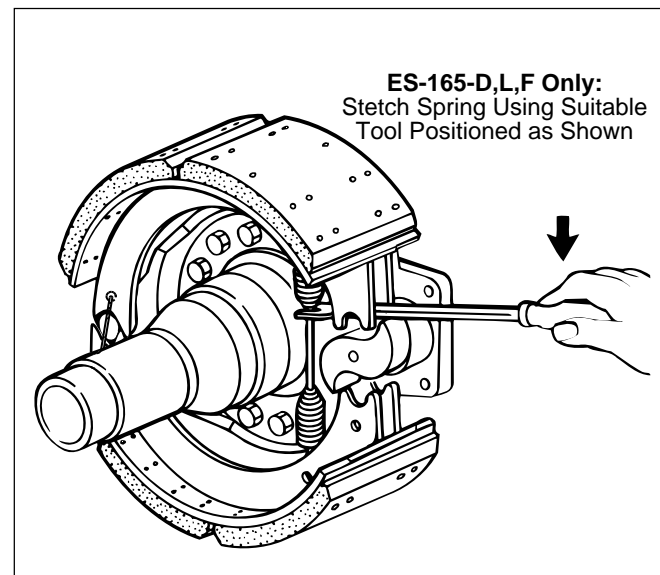

Figure 63. Shoe Return Spring Installation



Shoe And Lining Installation

6. For ES-165 5/6/7/8D, L, F, ES-150-4D, ES-150-8D, F & 6D only:

Assemble roller retainer on ends of roller as shown in Figure 64.

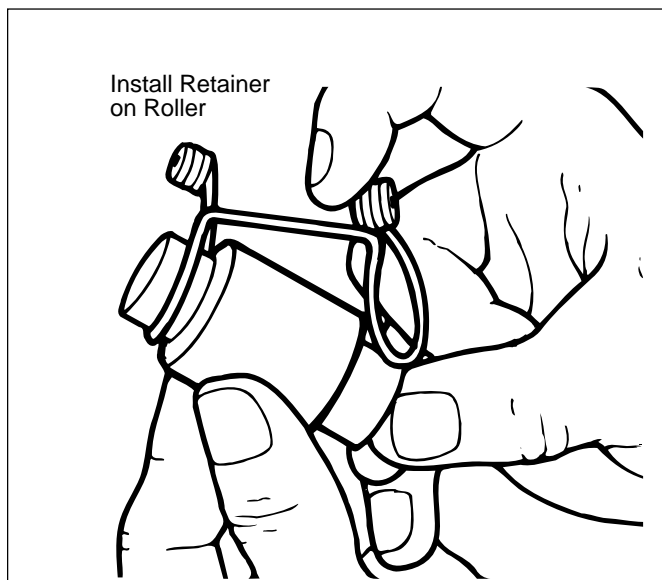

Figure 64. Roller Retainer Installation

7. Using a lever or large screwdriver, stretch shoe return spring to allow insertion of new pin and roller, (or roller and retainer assembly) on the lower shoe web. Refer to Figure 65.

NOTE: If drums are oversized, use oversize rollers, see **Inspection-Drum Inspection**.

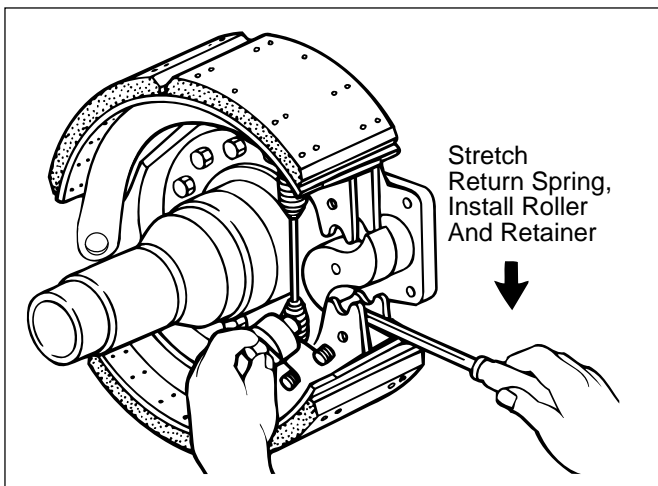

Figure 65. Shoe Return Spring Installation

8. For ES-165 5/6/7/8D, L, F, ES-150-4D, ES-150-8D, F & 6D only:

Position assembly in roller recess as shown. Squeeze loops and swing retainer into position to snap loops into web holes. Refer to Figure 66. Verify that both retainer loops are engaged in web holes before proceeding.

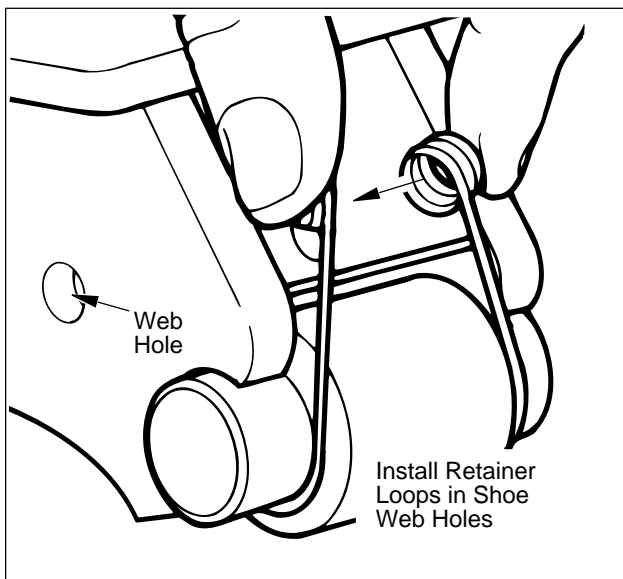

Figure 66. Retainer Installation

9. Repeat process on upper shoe.

NOTE: For all EB Models a roller retainer is not used.

ES-165-7M Heavy Duty Brake

! WARNING: The long term effects of non-asbestos fibers, have not been determined. Therefore, precautions should be used when handling these materials.

See **General Information / Lining Material Warning**

1. See **Inspection & Repair / Replacement** to verify that spider camshaft, bracket, and brake adjuster are serviceable and properly installed.
2. During shoe installation, lubricate:
 - Shoe roller recess.
 - Anchor pin - light film of grease.

! CAUTION: Use only grease conforming to NLGI grade #1, high-temperature, waterproof.

Do Not Lubricate:

- Cam head surface. For efficient operation, this surface must remain free of oil, grease or other contaminants.
3. After driving out old anchor pin bushings from spider, see **Removal/Disassembly - Shoe Removal**, press new anchor pin bushings in spider, aligning slot in bushing with tapped holes in spider. Refer to Figure 67.
 4. Lubricate anchor pins during installation (see step 2)

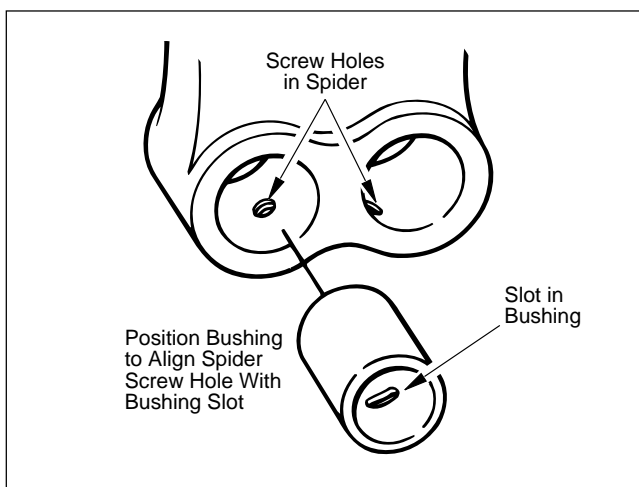

Figure 67. Anchor Pin Bushing Installation

5. Place the lower shoe in mounting position on spider, and install lower anchor pin, washers and retaining rings. Refer to Figure 68.

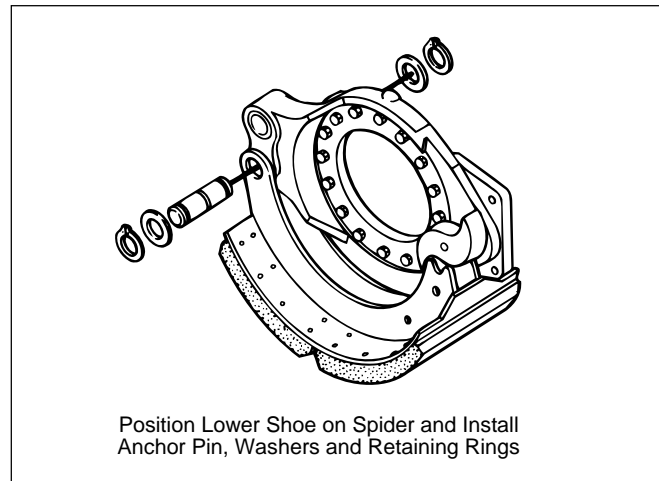

Figure 68. Lower Shoe and Anchor Pin Installation

6. Place upper shoe in mounting position on spider, and install upper anchor pin, washers and retaining rings. Refer to Figure 69.

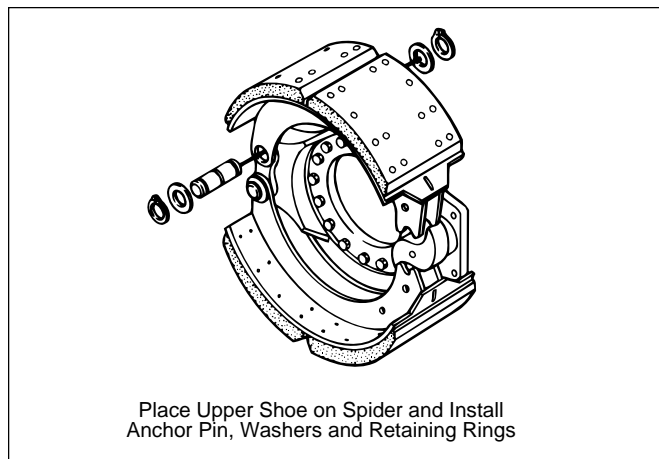

Figure 69. Upper Shoe and Anchor Pin Installation

7. Install cap screws in spider to secure anchor pins. Tighten to proper torque (see **Specifications** chart), then lock wire. **T**
Refer to Figure 70.

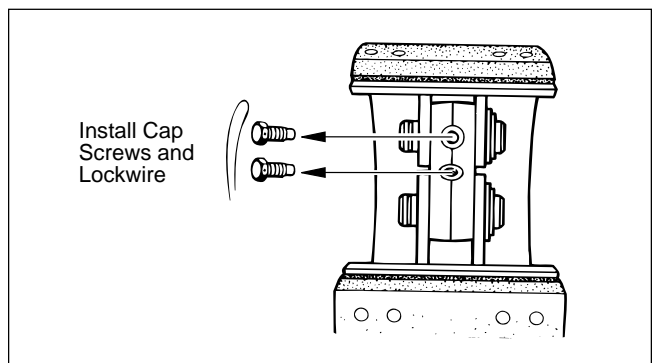

Figure 70. Cap Screw Installation



Shoe Installation

8. Install shoe return spring. Refer to Figure 71.

NOTE: A lever may be required to assist in hooking return spring.

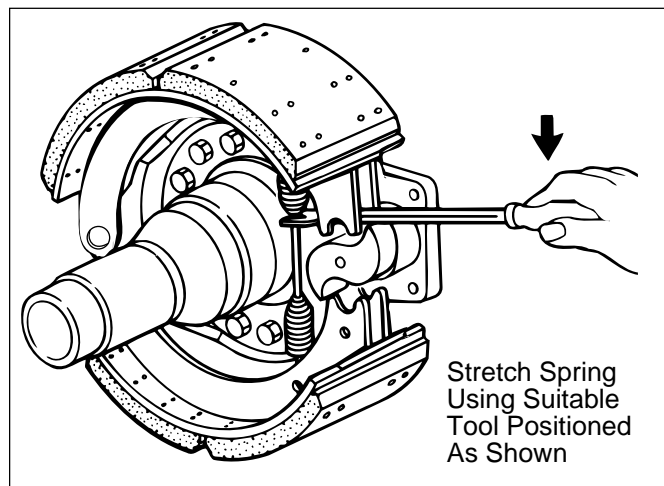

Figure 71. Shoe Return Spring Installation

NOTE: If drums are oversized, see **Inspection - Drum Inspection**.

9. Assemble roller retainer on ends of roller as shown below. Refer to Figure 72.

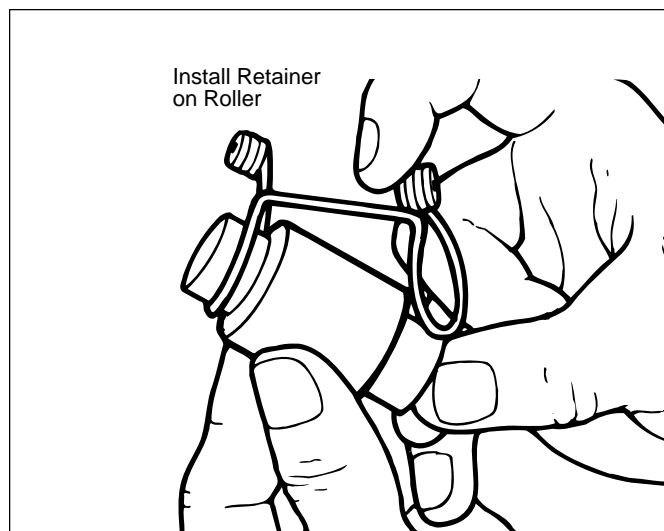

Figure 72. Roller Retainer Installation

10. Using a lever or large screwdriver, stretch shoe return spring to allow installation of new roller and retainer assembly on lower shoe web. Refer to Figure 73.

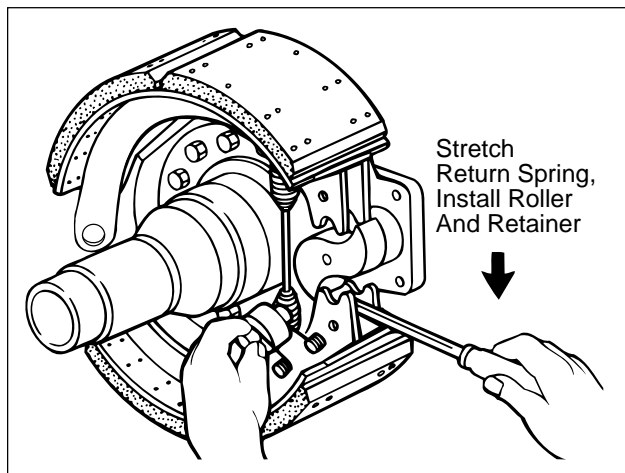

Figure 73. Roller and Retainer Installation

11. Position roller and retainer in shoe recess as shown in Figure 73. Squeeze loops and swing retainer into position to snap loops in shoe web holes. Refer to Figure 74. Verify that both retainer loops are engaged in web holes before proceeding.

12. Repeat process on upper shoe.

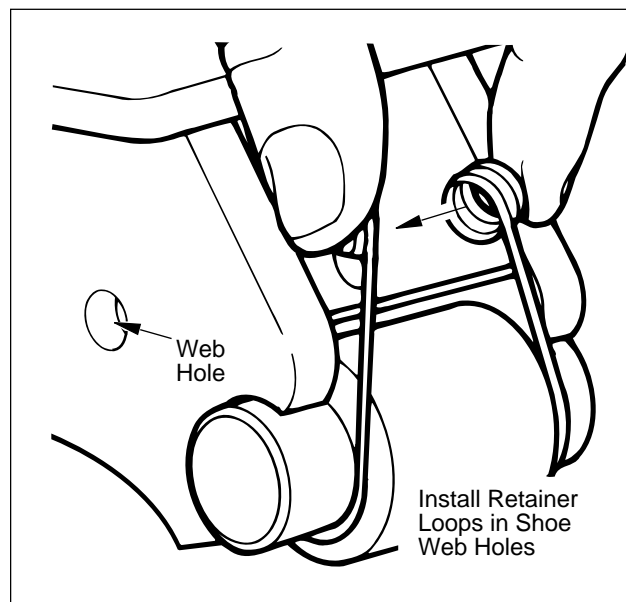

Figure 74. Retainer Installation

13. Install dustshield. Secure with cap screws, Tighten screws to correct torque, see **Specifications** chart. **T**

ES-165-7-H Severe Duty Brake



WARNING: The long term effects of non-asbestos fibers, have not been determined. Therefore, precautions should be used when handling these materials.

See **General Information/Lining Material Warning**

1. See **Inspection & Repair / Replacement** to verify that spider, camshaft, bracket, and brake adjuster are serviceable and properly installed.
2. During shoe installation, lubricate:
 - Roller inside diameter.
 - Anchor pin - light film of grease.



CAUTION: Use only grease conforming to NLGI grade #1, high-temperature, waterproof.

Do Not Lubricate:

- Cam head surface. For efficient operation, this surface must remain free of oil, grease or other contaminants.

NOTE: If rollers were removed, replace with new Bendix OEM rollers and pins.

3. Lubricate roller inside diameter (see Step 2), prior to installation. Assemble roller and pin to shoe and secure with groove pin. Stake casting area around groove pin. Refer to Figure 75.
4. After driving out old anchor pin bushings from spider, see **Removal/Disassembly - Shoe Removal**, press new anchor pin bushings in spider, aligning slots in bushing with tapered holes in spider. Refer to Figure 76.
5. Press anchor pin bushings in brake shoes. Refer to Figure 77.
6. Lubricate anchor pin prior to installation (see Step 2).
7. Place the lower shoe in position on the spider, and install lower anchor pin, washers and retaining rings. Refer to Figure 78.

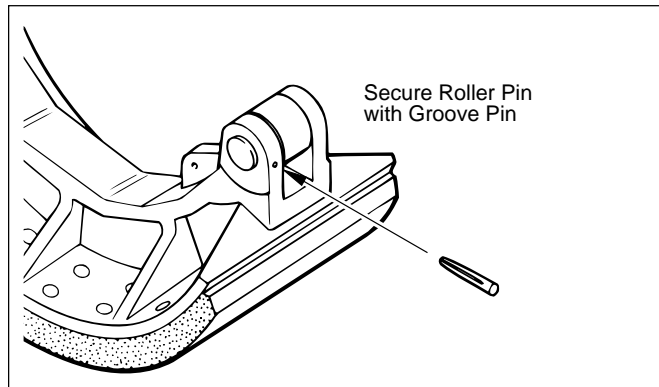

Figure 75. Groove Pin Installation

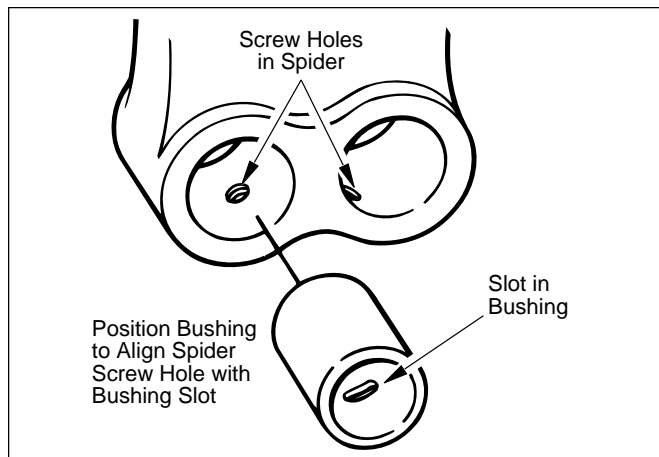

Figure 76. Spider Anchor Pin Bushing Installation

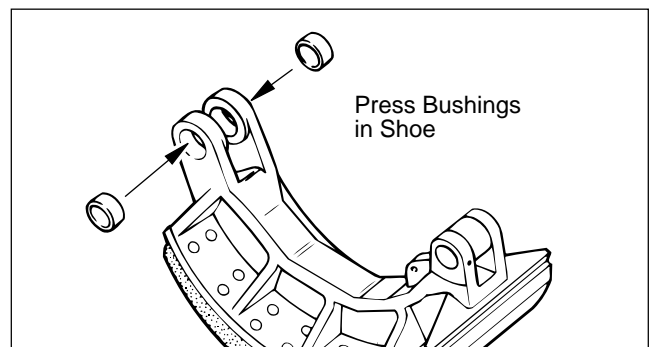

Figure 77. Shoe Anchor Pin Bushing Installation



Shoe Installation

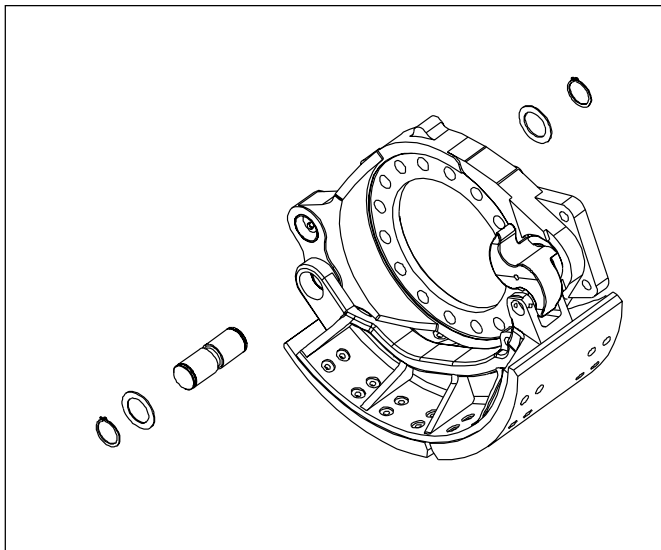

Figure 78. Lower Shoe Positioning

8. Connect a new return spring to lower shoe.
9. Position upper shoe for installation on spider (partially installed with shoe end disengaged from cam), then connect return spring to upper shoe. Refer to Figure 79.

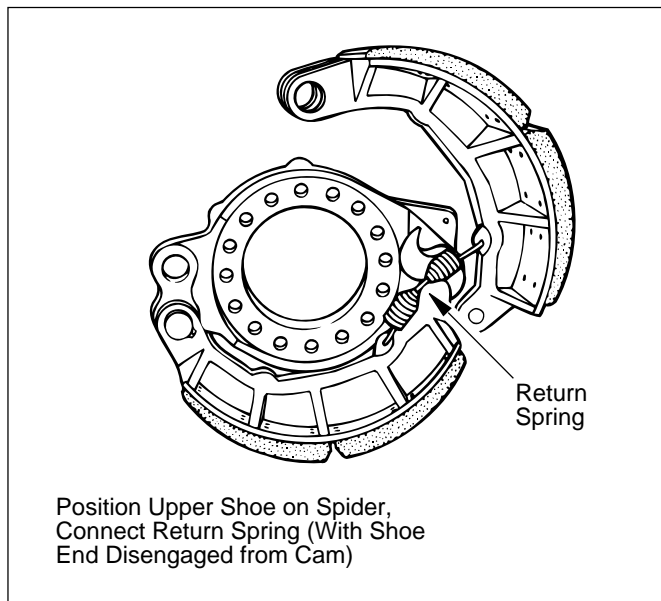

Figure 79. Upper Shoe Positioning

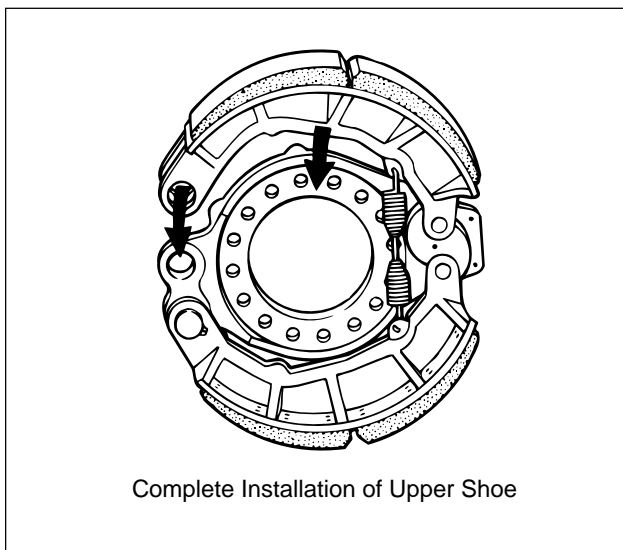

Figure 80. Upper Shoe Installation

10. Complete the installation of upper shoe and install anchor pin, washers and retaining rings. Refer to Figure 80.
11. Install cap screws in spider to secure anchor pins. Tighten screws to proper torque, see Specifications chart, then lock wire. Refer to Figure 81. **T**

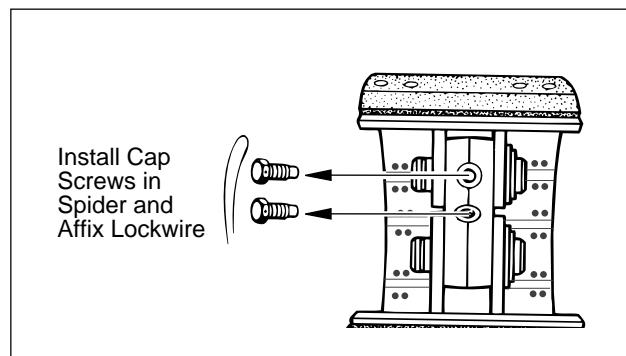

Figure 81. Lower Shoe and Anchor Pin Installation

12. Install dustshield. Secure with cap screws. Tighten screws to correct torque, see **Specifications** chart. **T**

Specification Chart

Fastener Torque Specifications

All EB/ES 165, 150-4D, 150-8D, F & 6D

Fastener	Torque	
	lbs./ft. – lbs./in.	N.m
Dustshield Retaining Clip Screws	48-60 lbs./in.	5-7 N.m
Dustshield to Spider Screws	150-180 lbs./in.	16.9-20.3 N.m
Air Chamber Bracket to Steel Stamped Spider Nuts	65-85 lbs.-ft.	88-115 N.m
Air Chamber Bracket to Cast Spider Bolts	65-85 lbs.-ft.	88-115 N.m
Air Chamber Mounting Nuts (7/16"-20 Nuts)	35-40 lbs.-ft.	48-54 N.m
Air Chamber Mounting Nuts (5/8"-18 Nuts)	110-115 lbs.-ft.	149-156 N.m
Lining Bolts/Nuts	For torque specs., refer to Installation Note in Lining Kit	
Anchor Pin Cap Screw (ES-165-7H, 7M)	120-150 lbs./in.	13.6-16.9 N.m

EB/ES-150-4L

Fastener	Torque	
	lbs./ft. – lbs./in.	N.m
Dustshield Attaching Screws	11-16 lbs./ft.	15-22 N.m
Air Chamber Bracket Nuts	55-65 lbs./ft.	75-88 N.m
Stabilizing Screw Nut	23-27 lbs./ft.	31-37 N.m
Anchor Pin Reinforcement Nuts	35-40 lbs./ft.	47-54 N.m
Anchor Pin Retaining Nut	475-525 lbs./ft.	644-712 N.m
Shoe Hold-Down Spring Screws	6-9 lbs./ft.	8-12 N.m

Key Dimensional Specifications

Minimum Lining Thickness (see Shoe and Lining Inspection)

EB/ES-150-4L	3/16" (4.76mm) or 1/16" (1.59 mm) from rivet heads
EB/ES-165	1/4" (6.4 mm) or 1/16" (4.76 mm) from rivet heads
Camshaft End Play (Axial)	.005" - .025" (.13 - .65 mm)
Camshaft Radial Play	.035" (.91 mm) maximum
Air Chamber Face to Clevis Pin Centerline (Trailer Axle Brakes)	6-1/2" \pm 1/8" (165.10 \pm 3.175 mm)
Air Chamber Face to Clevis Pin Centerline (Drive Axle Brakes)	2-5/8" \pm 1/16" (66.7 \pm 1.59 mm)
Wheel Bearing End Play	.001" - .005" (.025-.125 mm)

Air Chamber/Applied & Free Stroke

Maximum Air Chamber Size	Maximum Desired Applied Stroke	Free Stroke
30" (762.0 mm)	2" (50.8 mm)	3/8" to 5/8"
30" (762.0 mm) Long Stroke	2.5" (63.5 mm)	



*For more information, talk to your Bendix or Roadranger
representative, call 1-866-610-9709 or visit
www.foundationbrakes.com.*



Bendix Spicer
Foundation Brake LLC
A Bendix Commercial Vehicle Systems
and Dana Corporation Joint Venture

Roadranger
The Roadranger® System features
Bendix® brand foundation brakes.